



# X-Mind<sup>®</sup> DC

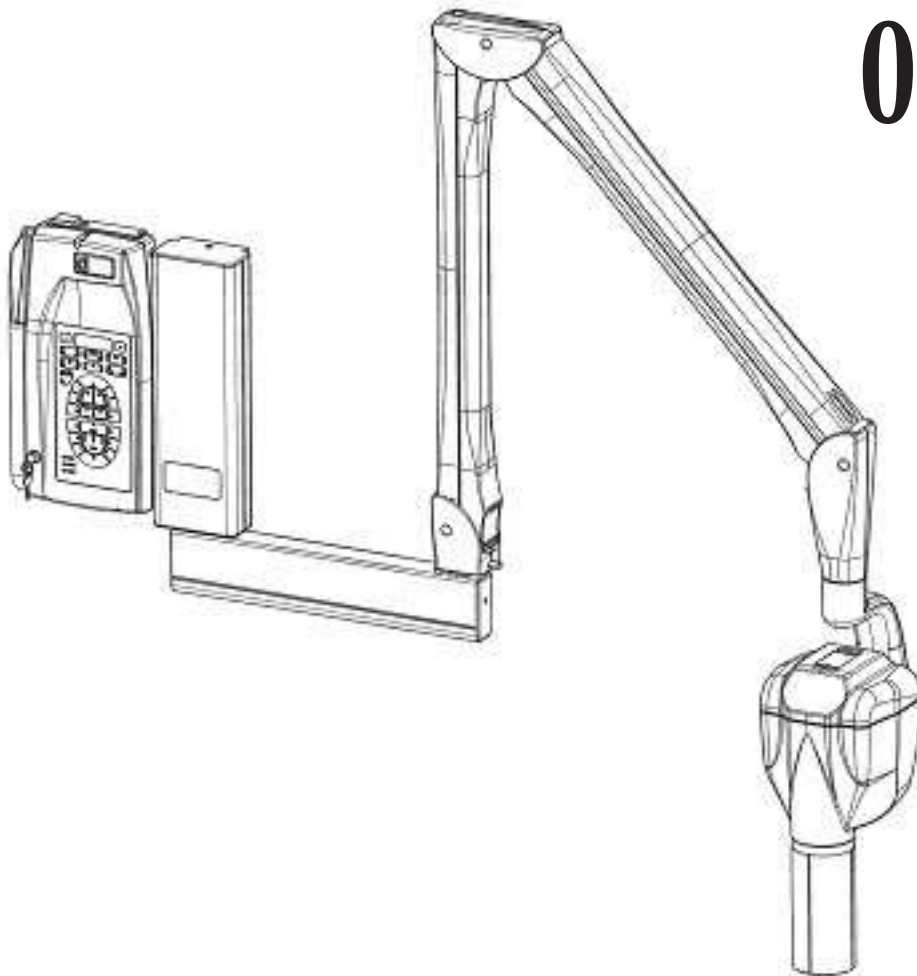
Installation manual / Manuel d'installation  
Installationshandbuch / Installatiehandleiding

# X-Mind<sup>®</sup> DC

Intraoral X-ray system at constant potential

## INSTALLATION & MAINTENANCE MANUAL

CE  
0434



This manual should always be kept in proximity to the device

## SUMMARY

INTRODUCTION	page	2
SUMMARY	page	3
PRELIMINARY INFORMATION	page	4
INSTALLER INFORMATION	page	5
1. "X-Mind DC" X-RAY SYSTEM	page	6
2. IDENTIFICATION TAGS	page	7
3. OVERALL DIMENSIONS	page	8
4. INSTALLATION SPECIFICATIONS	page	12
5. INSTALLATION	page	15
5.1 UNPACKING	page	15
5.2 ASSEMBLING THE WALL PLATE	page	16
5.3 ASSEMBLING THE BRACKET	page	18
5.4 ASSEMBLING THE PANTOGRAPH-TYPE ARM	page	20
5.5 CONNECTION TO THE FEEDING TERMINAL BOARD	page	21
5.6 ASSEMBLING THE TUBEHEAD	page	24
5.7 BALANCING THE PANTOGRAPH-TYPE ARM	page	27
5.8 ASSEMBLING THE "X-Mind DC" TIMER	page	30
5.9 TIMER ELECTRIC CONNECTION	page	32
6. CONTROL PANEL	page	34
7. SYSTEM CONFIGURATION	page	36
8. CHANGING THE CONFIGURATION	page	38
9. START-UP	page	40
10. CHECKING THE INSTALLATION	page	41
11. CHECKING THE EXPOSURE FACTORS	page	43
12. DIAGNOSTICS	page	44
13. CALIBRATION	page	45
13. ERROR MESSAGES	page	46
14. FUSE REPLACEMENT	page	48
15. MAINTENANCE	page	49
16. CLEANING OUTER SURFACES	page	50
17. SHOULD A REPAIR BECOME NECESSARY	page	51
18. DISPOSAL	page	51
19. ATTACHMENTS	page	52

## PRELIMINARY INFORMATION

Before beginning to use the “X-Mind DC” X-ray system, instructions contained herein should be carefully read and followed so as to obtain the best possible performance.

Always pay close attention to the **CAUTION**, **WARNING**, and **PLEASE NOTE** messages when operating the system.

### LEGEND



#### **CAUTION**

*The word **CAUTION** refers to events which might compromise the operator's personal safety or cause injuries to people.*



#### **WARNING**

*The word **WARNING** refers to events which might compromise the radiographic system's performance.*

#### **PLEASE NOTE**

The words **PLEASE NOTE** refer to special indications to facilitate maintenance or make important information clearer.

## INSTALLER INFORMATION



### **CAUTION**

*The installer is responsible for the installation, with regards to the system safety and operation.*

For safe and reliable installation of the “X-Mind DC” X-ray system it is advisable to:

- ✓ Check that the voltage mentioned in the rating plate matches the line voltage
- ✓ Install the “X-Mind DC” X-ray system according to the procedures described in this manual
- ✓ Provide the user with any information regarding the use of the “X-Mind DC” X-ray system pursuant to the manual
- ✓ Certify the work done by a Statement of Compliance
- ✓ Return the duly filled in warranty certificate to “Satelec® S.A.S”: if this is not done, the warranty is not valid

## 1. "X-Mind DC" X-RAY SYSTEM

The "X-Mind DC" X-ray system (Fig. 1) consists of:

- ① TUBEHEAD
- ② SPACER CONE
- ③ PANTOGRAPH-TYPE ARM
- ④ TIMER
- ⑤ WALL PLATE
- ⑥ BRACKET

### OPTIONAL

- long 12" (31 cm) cone
- short 8" (20 cm) cone
- long cone 12" (31 cm) with a rectangular section sized 44x35mm
- second "CONTROL BUTTON" with extension cable
- RX signaling lamp for external use: X-Mind LIGHT
- remote control button: X-Mind ECB

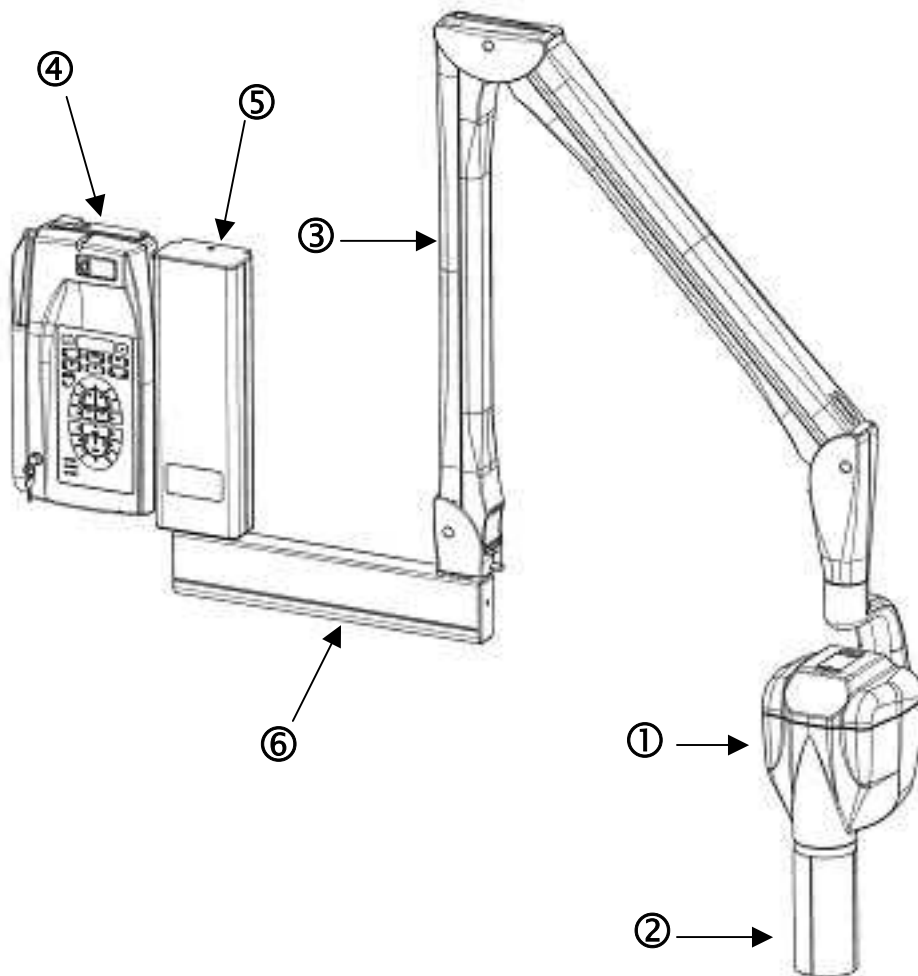
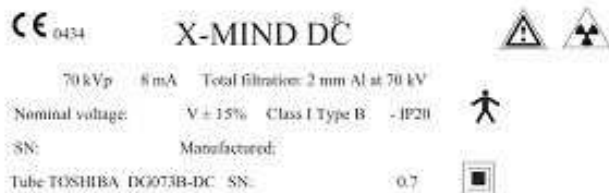


Fig. 1

## 2. IDENTIFICATION TAGS

The identification tags on the tubehead, on the timer and on the cone indicate the model name, the serial number, the manufacturing date and the symbols of the main technical characteristics.

Made by "de Götzen s.r.l. Italy" for SATELEC Z.I. du Phare 33700 Merignac France



ID TAG OF THE  
"X-Mind DC"  
TUBEHEAD

Made by "de Götzen s.r.l. Italy" for SATELEC Z.I. du Phare 33700 Merignac France



ID TAG OF THE  
"X-Mind DC"  
TIMER



ID TAG OF THE LONG 12" CONE



ID TAG OF THE SHORT 8" CONE



ID TAG OF THE RECTANGULAR CONE



GRADUATED SCALE TAG ON TUBEHEAD

### Pictograms used



This symbol guarantees that the X-ray system complies with the regulations contained in the European Directive EEC 93/42 regarding Medical Devices



The degree of protection against direct and indirect electric contacts is B type



Refer to Manual's instructions

**N**

"NEUTRAL" power supply wire

**L**

"PHASE" power supply wire

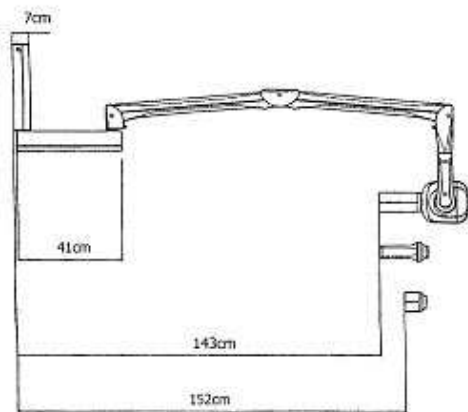
**T**

Ground cable

### 3. OVERALL DIMENSIONS

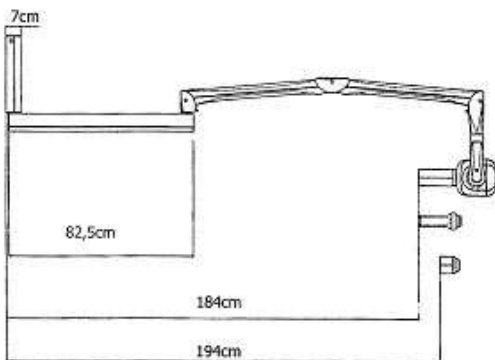
Fig. 1A, 1B, 1C give the overall dimensions of the possible supply conditions:

- SHORT BRACKET (optional) length 41 cm - 16.2"
- STANDARD BRACKET length 82,5 cm - 32.5"
- LONG BRACKET (optional) length 110 cm - 43.5"



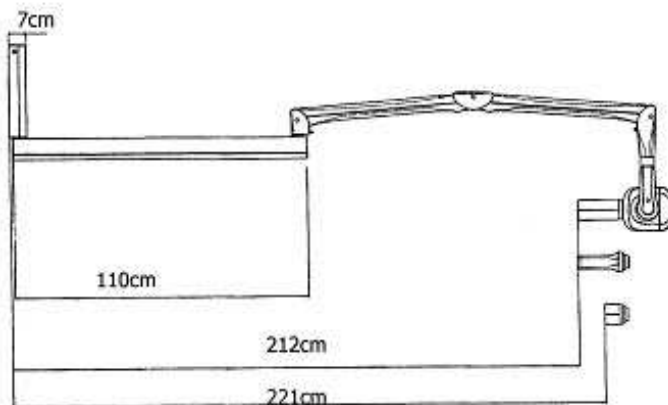
SHORT BRACKET 41 cm

Fig. 1A



STANDARD BRACKET 82.5 cm

Fig. 1B

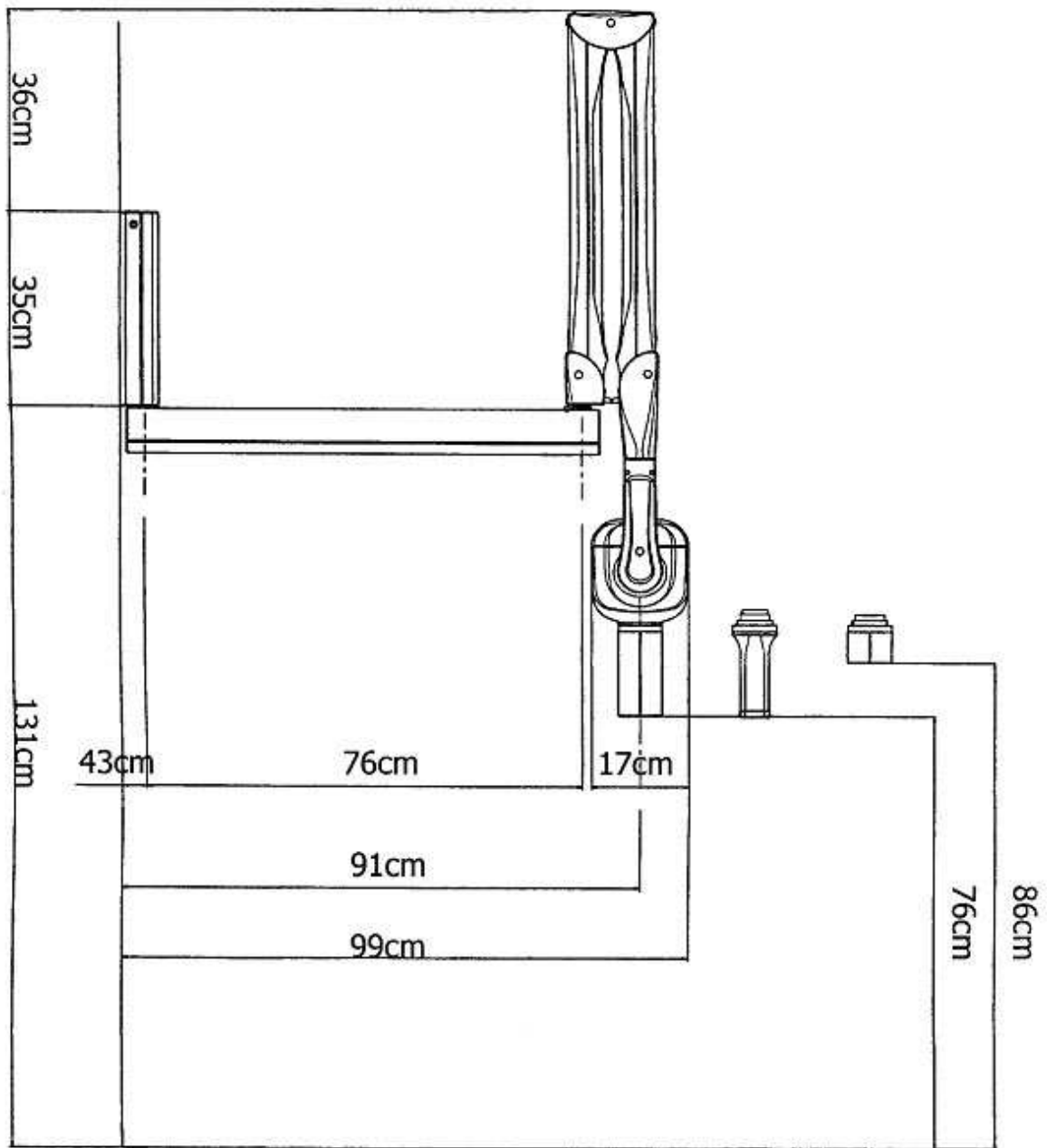


LONG BRACKET 110 cm

Fig. 1C



Fig. 2, 3A, 3B, 3C e 4 show the typical dimensions of the X-ray system:



STANDARD BRACKET 82.5 cm

Fig. 2

STANDARD BRACKET 82.5 cm

Fig. 3A

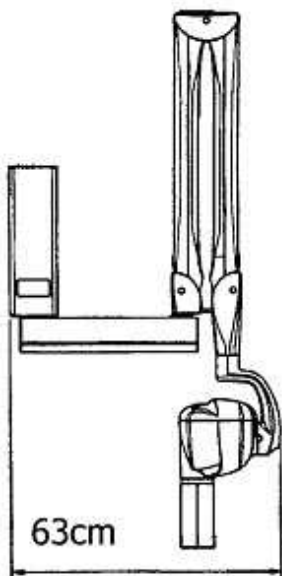
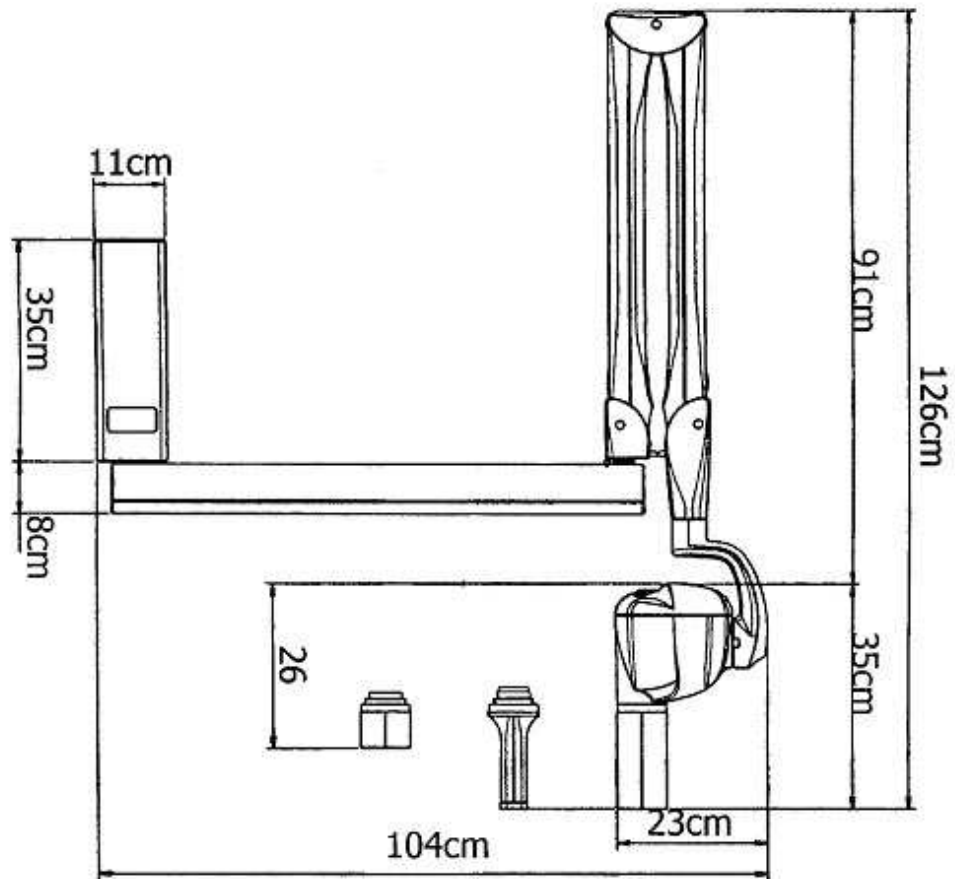


Fig. 3B  
SHORT BRACKET 41 cm

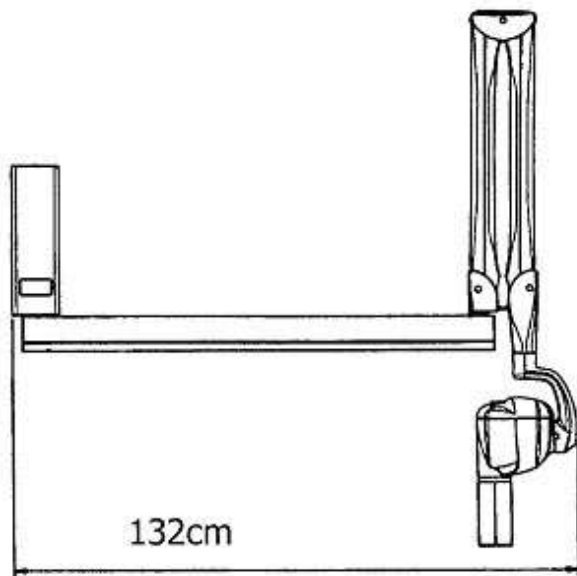


Fig. 3C  
LONG BRACKET 110 cm

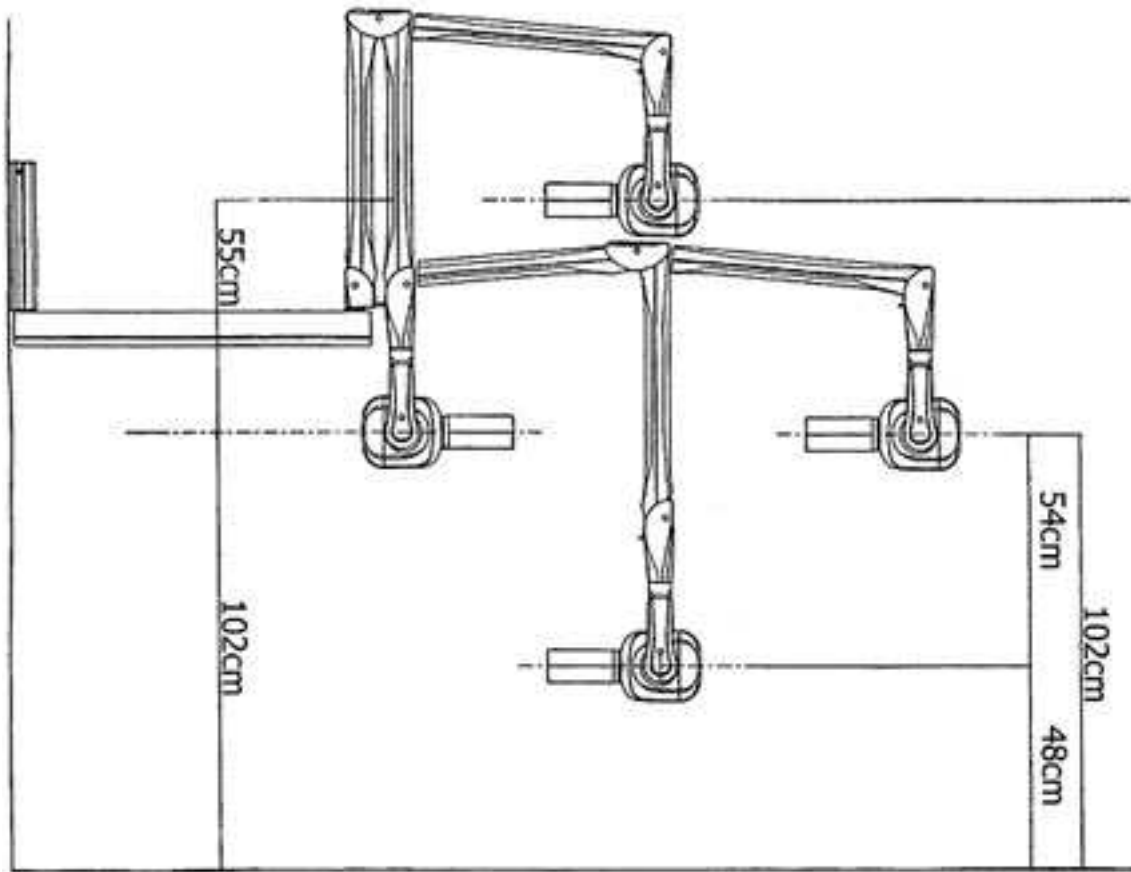


Fig. 4

## 4. INSTALLATION SPECIFICATIONS



### **WARNING**

*Prior to installing the X-ray system the Office Owner must ascertain that: the environment, the electrical system and the power supply comply with the requirements specified, otherwise he must provide the required adjustment works.*

### 1. ENVIRONMENT REQUIREMENTS

- a. The installation environment must be of appropriate width.  
Using the sizes and overall dimensions provided (*refer to §3 "OVERALL DIMENSIONS"*), ensure that no obstacles are present while positioning the X-ray system
- b. The environment must not be subject to explosion risks and must not be pressurized
- c. While operating, the ambient temperature must range within +5°C and +40°C
- d. The storage temperature must range within -15°C and +50°C
- e. The relative humidity must range within 25 % and 75 %

### 2. SUPPORTING WALL REQUIREMENTS

- a. The X-ray system supporting wall must be able to stand 200 kg tear at every point

#### **PLEASE NOTE**

The nature and consistency of the wall must be checked and if required, seek the support of a brickwork expert. Walls of uncertain consistency must be reinforced with a buried counter plate or with a sandwich type system.

### 3. ELECTRICAL SYSTEM REQUIREMENTS

- a. The electrical system must comply with regulations in force
- b. The electrical system must be able to supply the power and voltage required in the Manufacturer's rating plate of the X-ray system as shown in Chart 1

**CHART 1**

MANUFACTURER'S RATING PLATE		<b>230 V ± 15%</b>	<b>115 V ± 15%</b>
<b>ELECTRICAL SYSTEM</b>	RATED LINE VOLTAGE	230 V	115 V
	MINIMUM VOLTAGE	196 V	98 V
	MAXIMUM LINE VOLTAGE	264 V	132 V
	FREQUENCY	50/60 Hz	50/60 Hz
	POWER ABSORBED DURING EXPOSURE	850 W	850 W

#### 4. ELECTRICAL LINE REQUIREMENTS

- a. The electrical line must be "single-phase" type
- b. It is essential that a 16A - 250V, magnetothermal differential switch be fitted upstream of the X-ray system, with differential protection  $I_n \leq 30\text{mA}$  (refer to §20 "ATTACHMENTS")
- c. The power cords of the timer and the tubehead connection conductors with must be two-pole + ground, and in proportion to the length of the power cord, as shown in Chart 2

**CHART 2**

POWER SUPPLY VOLTAGE	MINIMUM CONDUCTOR SECTION	MAXIMUM LINE LENGTH
196V to 264V	1.5 mm <sup>2</sup>	10 meters
	2.5 mm <sup>2</sup>	20 meters
98V to 132V	1.5 mm <sup>2</sup>	10 meters
	2.5 mm <sup>2</sup>	20 meters

**PLEASE NOTE**

For longer lines, the cord section must be increased in proportion.

- d. The communication cables (C11, C12 - C21, C22) between the timer and X-Ray must be two-pole, twisted and shielded with  $>0.25 \text{ mm}^2$  section (example: Belden 9501 type)
- e. The cables (S11, S12 - S21, S22) connecting the timer and the signal lamps located outside the surgery must be two-pole  $> 0.5 \text{ mm}^2$
- f. The electrical line characteristics must comply with Chart 3

**CHART 3**

LINE VOLTAGE		230 V ± 15%	115 V ± 15%
ELECTRICAL LINE	MAXIMUM LINE VOLTAGE DROP	3%	3%
	MAXIMUM LINE APPARENT RESISTANCE	0.5 ohm	0.5 ohm

## 5. ELECTRICAL CONNECTIONS



### **WARNING**

*Prior to installing the X-ray system, it is advisable that all the electrical connections be in place.*

### Timer electric connections



### **CAUTION**

*According to the relevant standard, the timer must be installed in a position allowing the operator to always control the X-ray exposure.*

On the timer installation wall, suitable conduits for the following electric cables must be provided, pursuant to the electrical installation diagram (*refer to §20 “ATTACHMENTS”*):

- a. Timer electrical cables  
(*refer to §5.9 “TIMER ELECTRIC CONNECTIONS”*)
- b. Cables connecting the timer and the tubehead  
(*refer to §5.9 “TIMER ELECTRIC CONNECTIONS ”*)
- c. Cables connecting the timer and the RX signal lamp/s for external use:  
X-Mind LIGHT (OPTIONAL)
- d. Cables connecting the timer and the remote control button:  
X-Mind ECB (IF PROVIDED)

### Tubehead electrical connections

On the wall plate installation wall, a suitable conduit for the cable connecting the timer and tubehead must be provided  
(*refer to §5.5 “CONNECTION TO THE POWER SUPPLY TERMINAL BOARD”*)

## 5. INSTALLATION



### CAUTION

The “ X-Mind®DC ” X-ray system must be installed by professionally trained technicians, who must be able to certify their work with a Statement of Compliance.



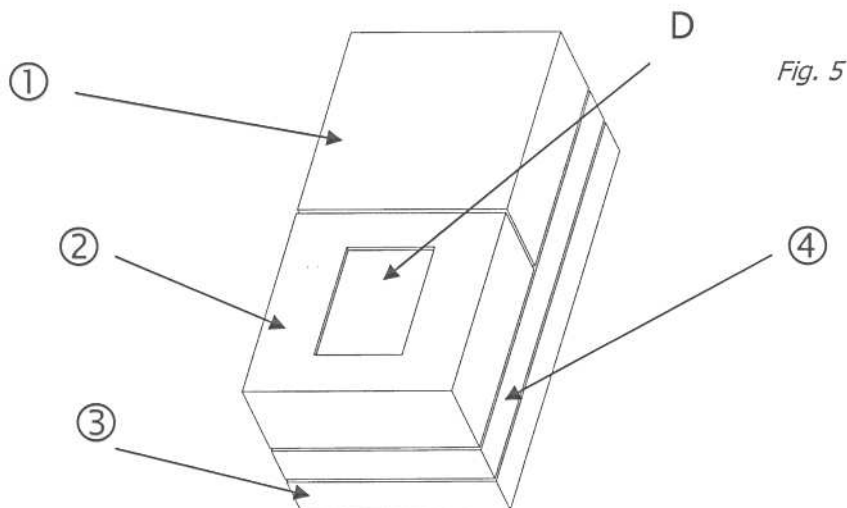
### WARNING

Prior to installing the X-ray system, it is advisable to ensure that all needed requirements have been met (refer to §4 “INSTALLATION SPECIFICATIONS”)

## 5.1 UNPACKING

The components of the “ X-Mind®DC ” radiographic system are duly packed within a carton box, as shown in the following sketch (Fig. 5):

- D** DOCUMENTS: INSTRUCTION MANUAL, INSTALLATION & MAINTENANCE MANUAL, AND WARRANTY CARD
- ① X-Mind®DC TUBEHEAD PACKAGING
- ② X-Mind®DC TIMER + RX SIGNALING LAMP FOR EXTERNAL USE X-Mind® LIGHT (OPTIONAL) + REMOTE CONTROL BUTTON X-Mind® ECB (OPTIONAL) PACKAGING
- ③ PANTOGRAPH-TYPE ARM PACKAGING
- ④ WALL PLATE + BRACKET PACKAGING



### PLEASE NOTE

Prior to installation, duly check all components.

### PLEASE NOTE

The carton and the polystyrene foam can be completely recycled and can be disposed of by authorized recycling companies.

### PLEASE NOTE

The original packaging should be stored in the event the equipment is returned for repairs.

## 5.2 ASSEMBLING THE WALL PLATE



### WARNING

To fix the wall plate, **DO NOT** use plastic or rubber anchor screws.  
For cement or solid/hollow brick walls, use metal anchor screws Ø12 (NOT included).

### ASSEMBLY INSTRUCTIONS (Fig. 6)

1. Take the wall plate out of the packaging (refer to Fig. 5) and take the drilling template ①
2. Position the drilling template ① on the X-ray system installation wall, at the required height (130 cm from the base is the suggested height)
3. Secure the template with adhesive tape
4. Check the holes for vertical and horizontal alignment, using a plumb line
5. Mark the wall plate anchor holes
6. Mark the holes for the electric cables connecting the timer to the tubehead

### PLEASE NOTE

To prevent any flaking in the white coat and to control the center distances between the holes, it is advisable to start drilling with a Ø7 bit, increasing this size gradually.

7. Drill the wall plate anchor holes
8. If required, drill the holes for the electric cables connecting the timer to the tubehead
9. Remove the template ① and insert the suitable anchor screws, according to the wall's characteristics ②
10. Unscrew the screw ④ and remove the plug ③ from the wall plate
11. Withdraw the sliding cover ⑤
12. Apply the wall plate ⑥ to the wall and insert the screws ⑦ with the appropriate washers, then tighten them alternately
13. Ensure that the wall plate is solidly attached to the wall

### PLEASE NOTE

If the wall is not perfectly plumb, insert a suitable shim between the wall and the wall plate, in order to prevent warping.



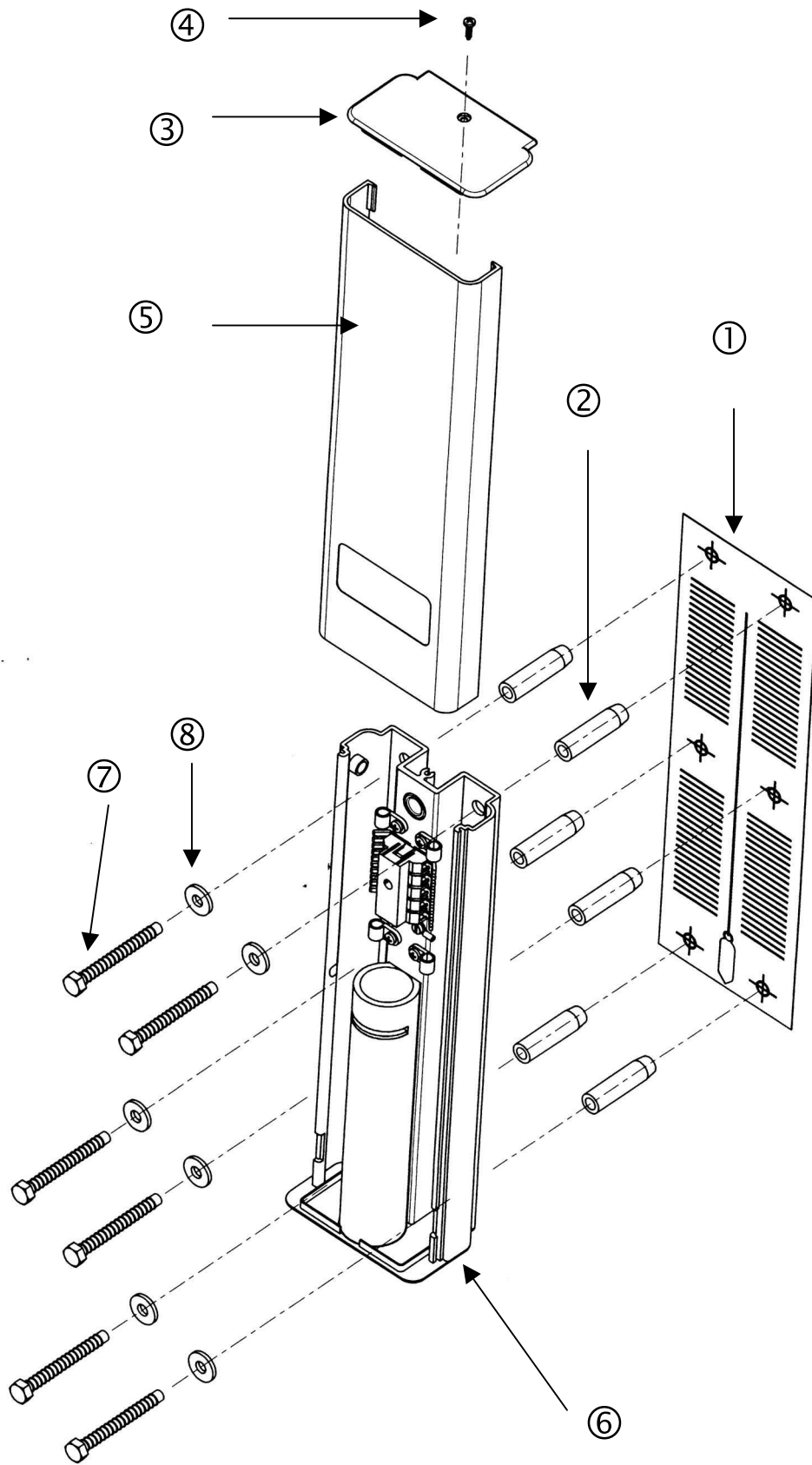


Fig. 6

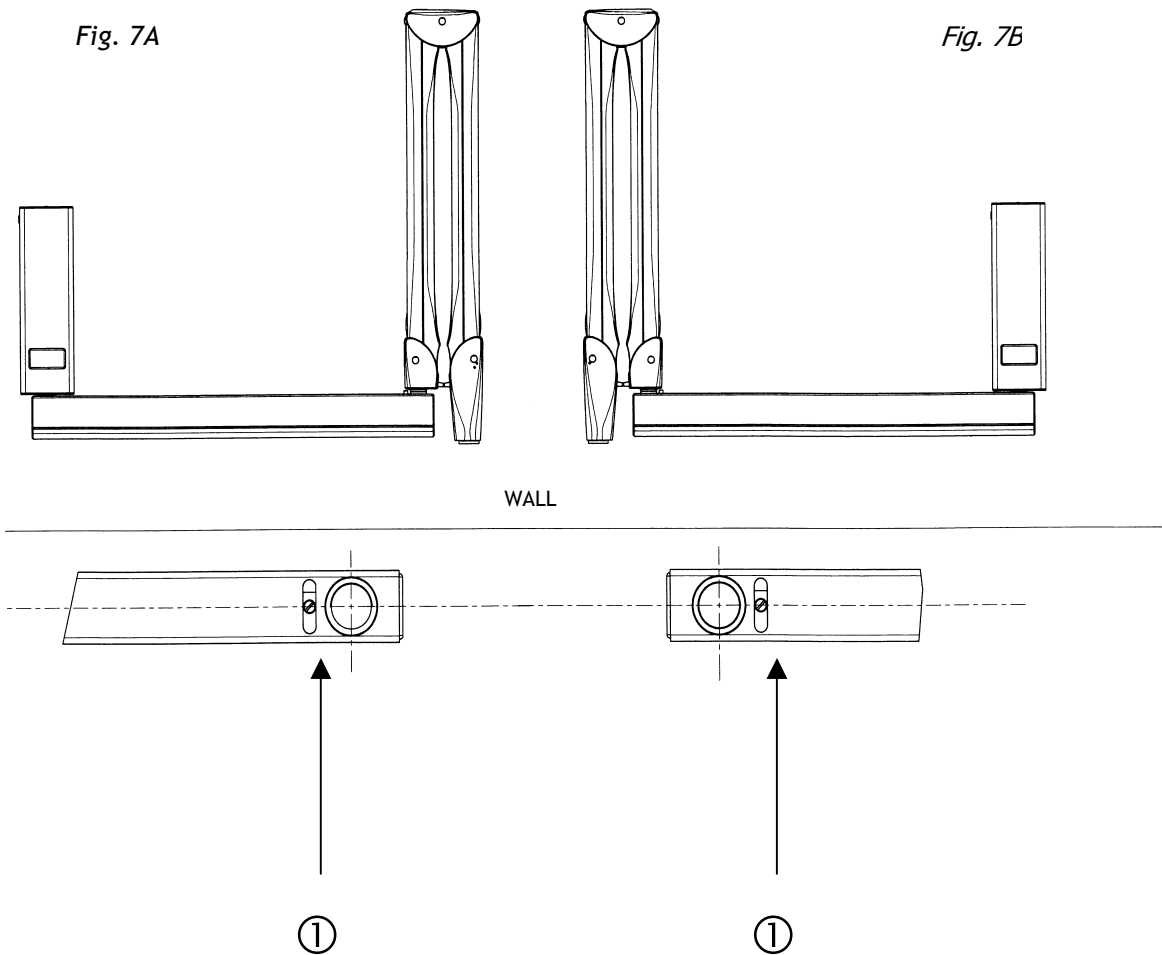
### 5.3 ASSEMBLING THE BRACKET

#### PLEASE NOTE

The brackets come in the following lengths: 41 cm - 82,5 cm - 110 cm  
The 82.5 cm and 110 cm brackets are provided with a stop key ① (Fig. 7A and 7B) to prevent the electrical cable from twisting.

#### PLEASE NOTE

Generally, the stop key is installed so that the equipment position at rest is on the right side, viewed from the front of the wall plate (Fig. 7A).  
Should the position at rest be on the left side, the stop key must be rotated by 180° (Fig. 7B).



After fixing the plate to the wall, assemble the bracket, using the following procedure (Fig. 8):

1. Take the bracket out of the packaging (refer to Fig. 5)
2. Insert the bracket pin ② into the wall plate ① (upwards)
3. Insert the supporting rest ③

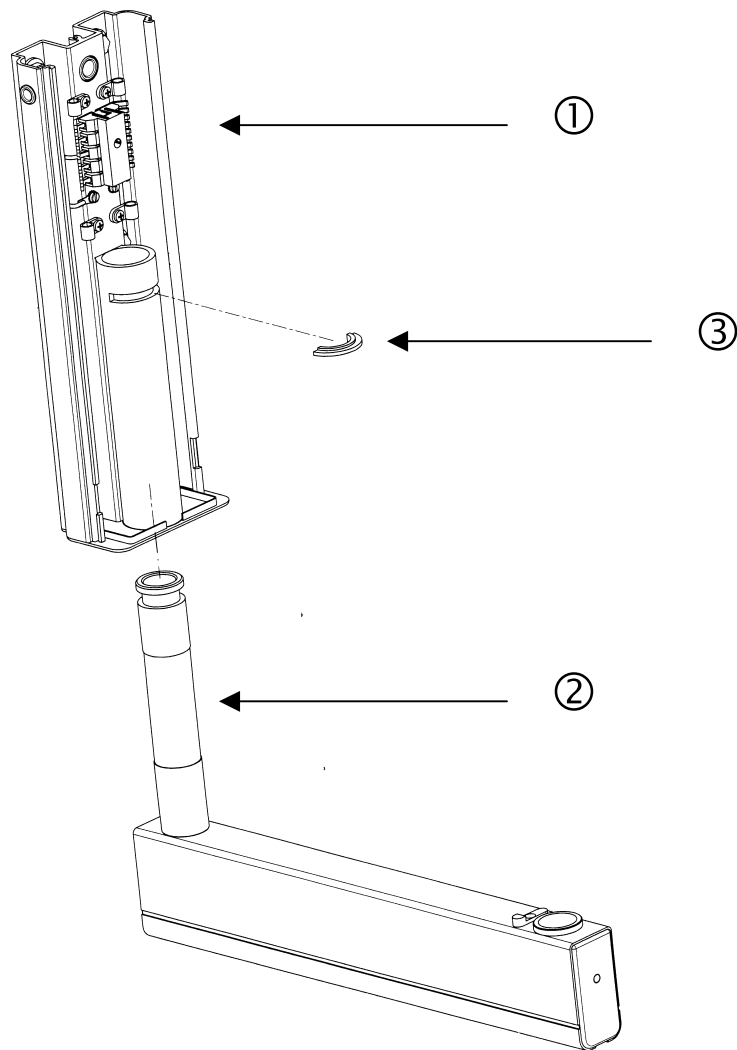


Fig. 8

**PLEASE NOTE**

Prevent all foreign matter (ground, dust, cement, etc. ) from settling on the pin seat.  
The pin must slide freely in its seat. If required, thoroughly clean and lubricate with “molikote D” lubricant.

**PLEASE NOTE**

Carefully check that the bracket is parallel to the floor, using a water level.

## 5.4 ASSEMBLING THE PANTOGRAPH-TYPE ARM

### ASSEMBLY INSTRUCTIONS (Fig. 9)

1. Take out the pantograph-type arm from the packaging (*refer to Fig. 5*)
2. Remove the bracket plug ① by unscrewing the set screw ②
3. Insert the bracket guard wafer ③
4. Insert the pantograph group cable ⑤ into the washer ④ and then the pantograph pin ⑥

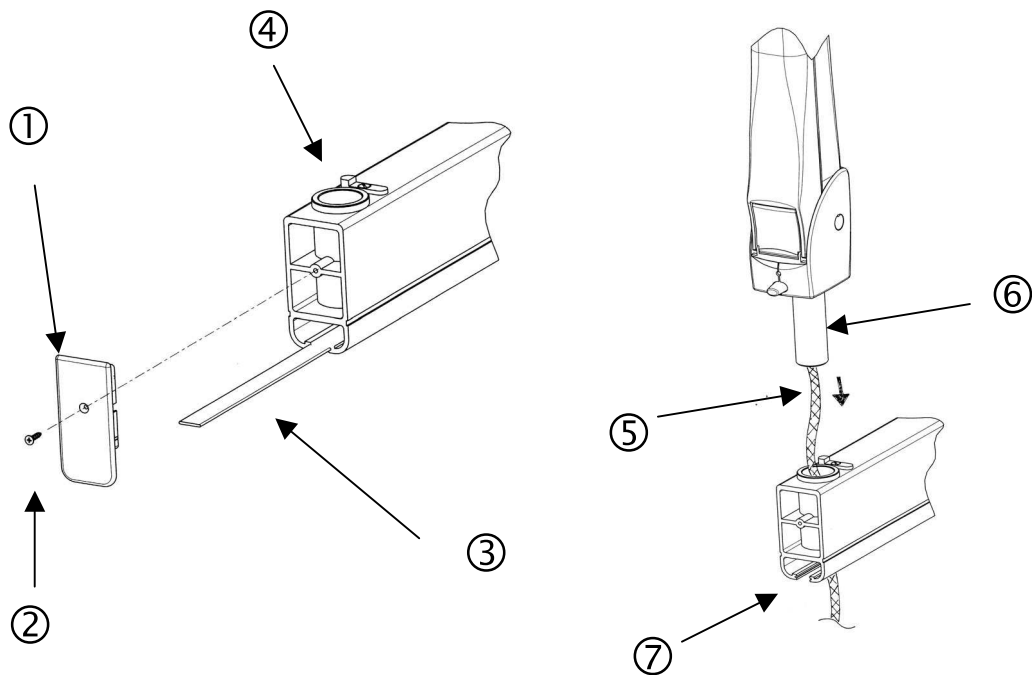


Fig. 9

5. If required, clean the pin and the washer and lubricate with “molikote D” lubricant
6. Insert the electric cable into the bracket housing ⑦
7. Assemble the guard wafer
8. Insert the cable into the bracket and push it until it reaches the pin outlet near the supply terminal board

## 5.5 CONNECTION TO THE FEEDING TERMINAL BOARD



### **CAUTION**

*For electrical safety, it is essential that the ground conductors be correctly connected.*



### **WARNING**

*The length of the electrical cable and of the communication cable is suitable for 82.5 cm brackets.*

*DOT NOT tamper with the terminals arrangement when 41 cm long brackets are used.*

*The excess cable must be stored in the housing provided.*

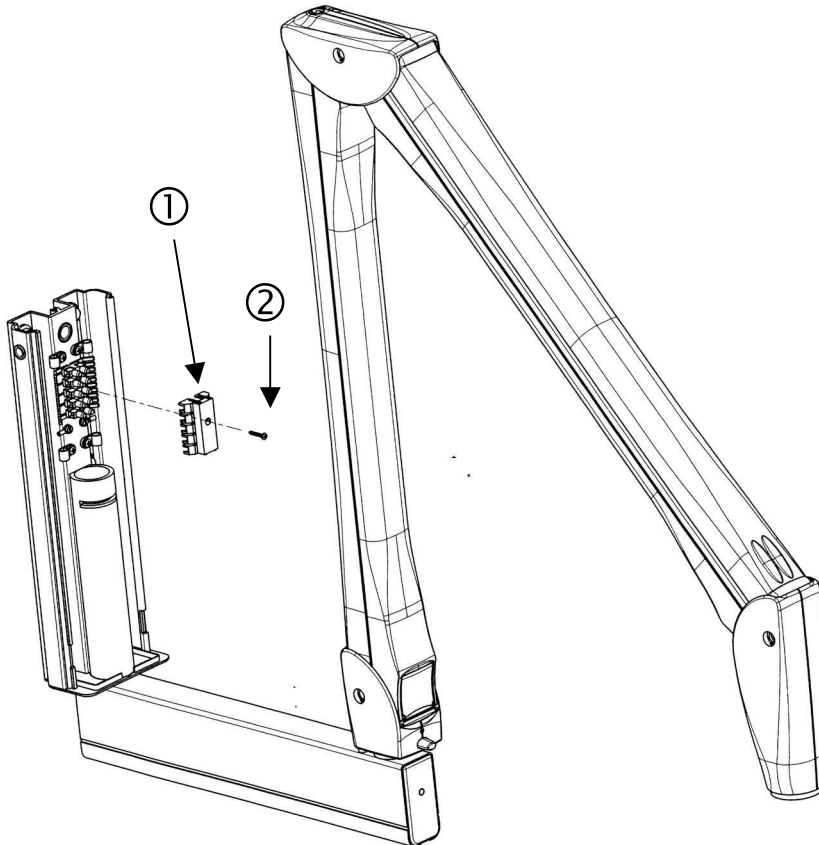


### **WARNING**

*In case of electric power supply type PHASE - PHASE the higher value must be taken using a tester and entered in L.*

**OPERATING INSTRUCTIONS (Fig. 10)**

1. Remove the terminal board cover ① by unscrewing the set screw ②



*Fig. 10*

2. Proceed with the electrical connection as shown in Fig. 11

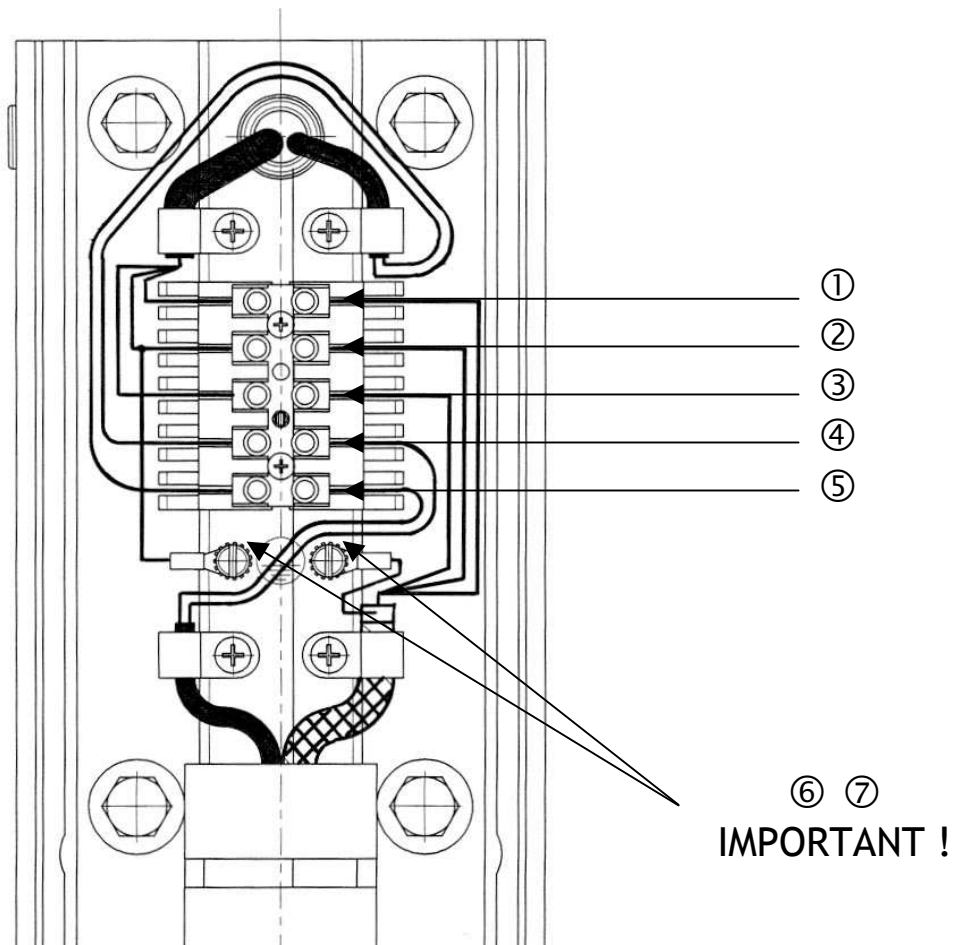


Fig. 11

**TERMINAL BOARD CONNECTION DIAGRAM**

①	BROWN	L (line)
②	YELLOW GREEN	T (ground)
③	BLUE	N (neutral)
④	BLACK	COMMUNICATIONS
⑤	RED	COMMUNICATIONS
⑥	YELLOW GREEN	T (ground)
⑦	YELLOW GREEN	T (ground)

THE COMMUNICATIONS CABLES ARE NOT POLARIZED

3. Connect the pantograph cable shield to the grounding potential ⑥
4. Connect the wall plate to the grounding potential ⑦
5. Clamp the cables with the cable clamps provided
6. Reassemble the terminal board cover (refer to ① Fig. 10)

## 5.6 ASSEMBLING THE TUBEHEAD

### ASSEMBLY INSTRUCTIONS

1. Remove the tubehead from the packaging (*refer to Fig. 5*)
2. Check that all the rating data match the power supply voltage
3. Remove both guards from the pantograph-type arm by loosening the appropriate screws (*Fig. 12*)



*Fig. 12*

4. Using a bit, detach the front coupling device (*Fig. 13A*)
5. Remove both guards (*Fig. 13B*)



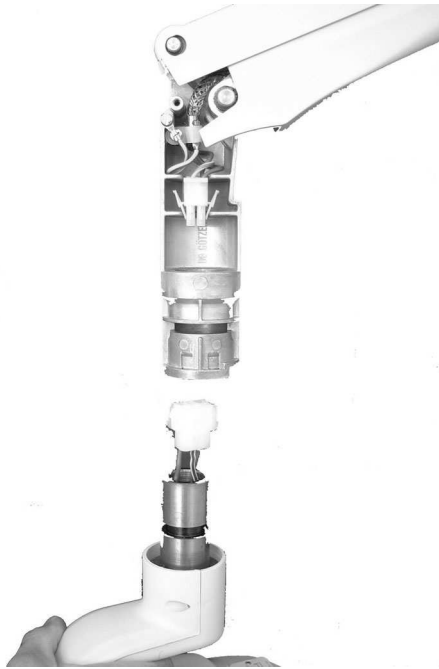
*Fig. 13A*



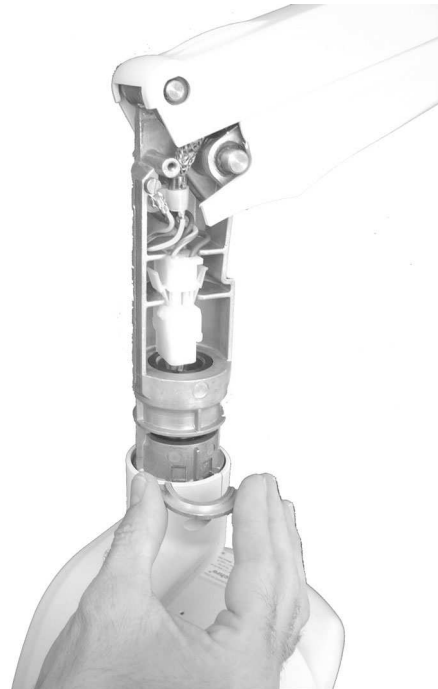
*Fig. 13B*



6. Insert the tubehead pin into the pantograph head (*Fig. 14A*) and insert the support (*Fig. 14B*)

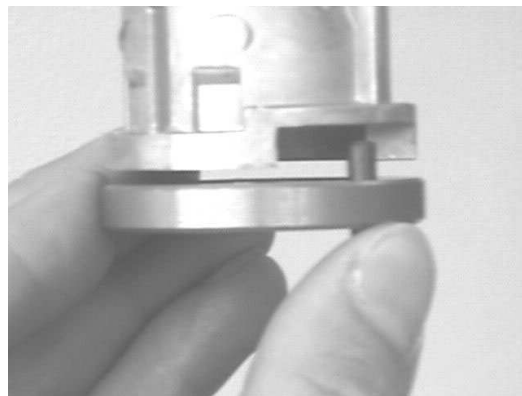


*Fig. 14A*



*Fig. 14B*

7. Check that during insertion, the pin of the rotation prevention device is correctly inserted into the seat located on the pantograph head (*Fig. 15*)



*Fig. 15*

8. Couple the pantograph and tubehead connectors and insert them into their seats (*Fig. 16*)



*Fig. 16*

## 5.7 BALANCING THE PANTOGRAPH-TYPE ARM



### CAUTION

*The pantograph-type arm must be adjusted only when the tubehead is assembled .*



### WARNING

*To prevent damage to the internal mechanism while making adjustments and executing the balancing tests, the adjustment key must not be left in place.*



### WARNING

*The key provided must be carefully stored.*

### PLEASE NOTE

To reach the "X" adjustment screw "ARM A" must be put in vertical position.

To reach the "Y" adjustment screw "ARM B" must be put in horizontal position.

The adjustment key provided can be inserted only under the above conditions (Fig. 17)

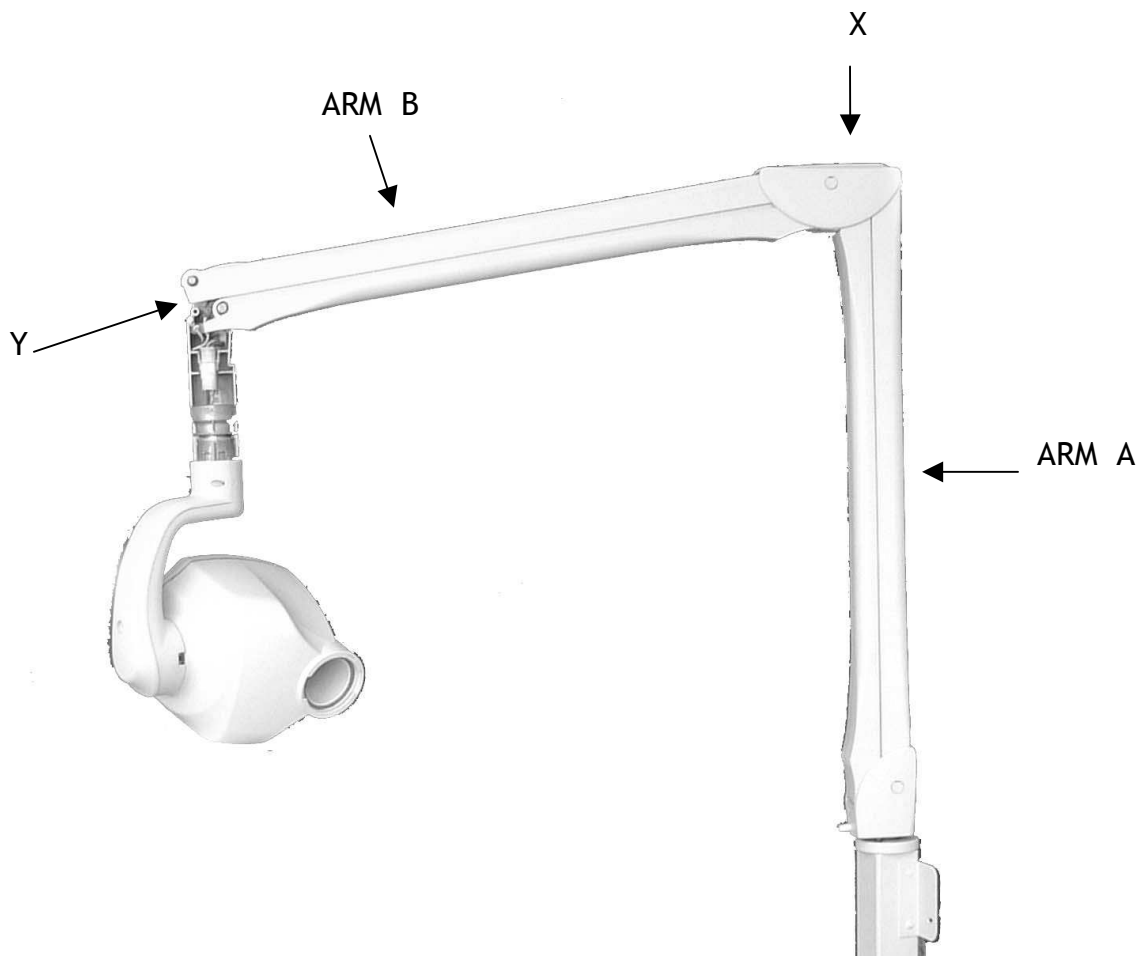


Fig. 17

Procedure to be followed to correctly balance the pantograph-type arm (*refer to Fig. 17*):

**1. “ARM A” BALANCING**

**PLEASE NOTE**

The pantograph-type arm is supplied with “ARM A” already preloaded.  
“ARM B” is supplied unloaded for safety reasons.

**2. “ARM B” BALANCING**

For correct balancing, proceed as follows:

1. “ARM A” VERTICAL
2. “ARM B” HORIZONTAL
3. INSERT THE ADJUSTMENT KEY IN “Y”
4. LOAD THE SPRING WITH 22 TURNS
5. WITHDRAW THE KEY

**3. CHECKING THE BALANCING**

To check the balancing, proceed as follows:

BRING “ARM B” TO THE VARIOUS POSITIONS

if it does not maintain the correct position:

1. BRING “ARM B” BACK TO THE HORIZONTAL POSITION
2. INSERT THE ADJUSTMENT KEY IN “Y”
3. ROTATE THE ADJUSTMENT KEY BY HALF TURN:
  - CLOCKWISE IF IT TENDS TO COME DOWN
  - COUNTERCLOCKWISE IF IT TENDS TO GO UP
4. WITHDRAW THE KEY

**PLEASE NOTE**

Repeat the test and adjustment until “ARM B” is steady and stable in all positions, even when “ARM A” is completely extended.

**4. READJUSTMENT OF “ARM A”**

If it does not maintain the required position:

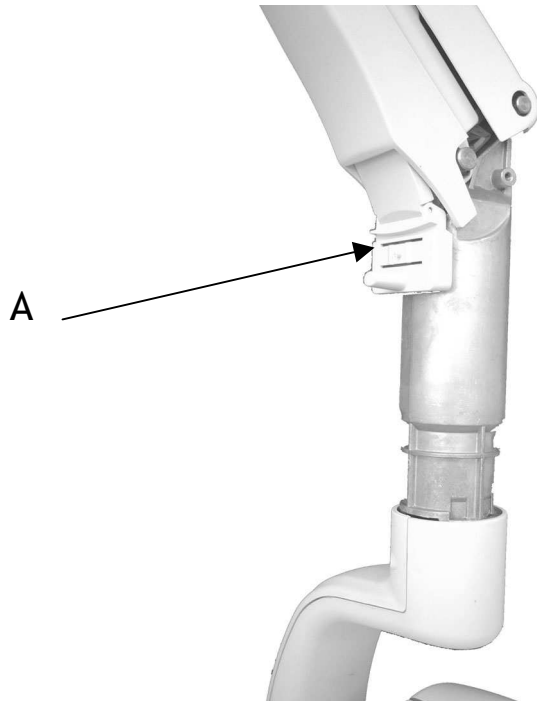
1. BRING “ARM A” TO THE VERTICAL POSITION AGAIN
2. INSERT ADJUSTMENT KEY IN “X”
3. ROTATE ADJUSTMENT KEY BY HALF TURN:
  - CLOCKWISE IF IT TENDS TO COME DOWN
  - COUNTERCLOCKWISE IF IT TENDS TO GO UP
4. WITHDRAW THE KEY

**PLEASE NOTE**

Repeat the test and adjustment until “ARM A” is steady and stable in all positions, even when “ARM B” is completely extended.

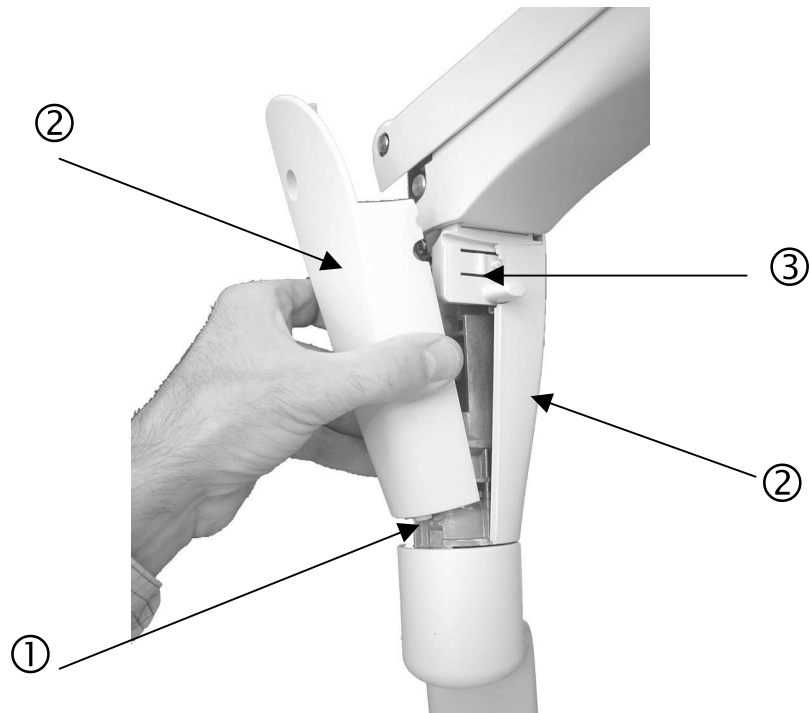
Upon completion of balancing:

1. Insert the movable finish (A) between the pantograph-type arm guard and the metal frame (*Fig. 18*)



*Fig. 18*

2. Insert the pins ① of the guards ② into their slots; then position them and ensure that the movable finish ③ is coupled to the guards (*Fig. 19*)



*Fig. 19*

## 5.8 ASSEMBLING THE “X-Mind®DC” TIMER



### CAUTION

Check that the cable conduits are present in the timer installation wall; check the compliance of the power supply with the installation specifications (refer to §.4 “INSTALLATION SPECIFICATIONS”).



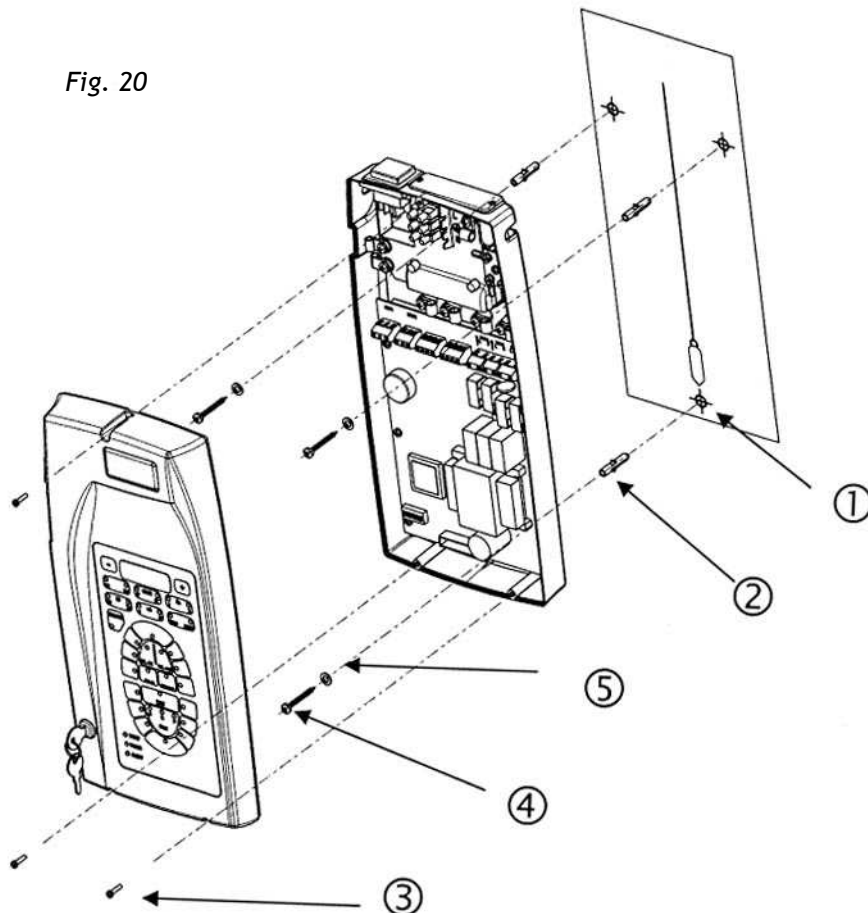
### CAUTION

Check that the rating data match the power supply voltage.

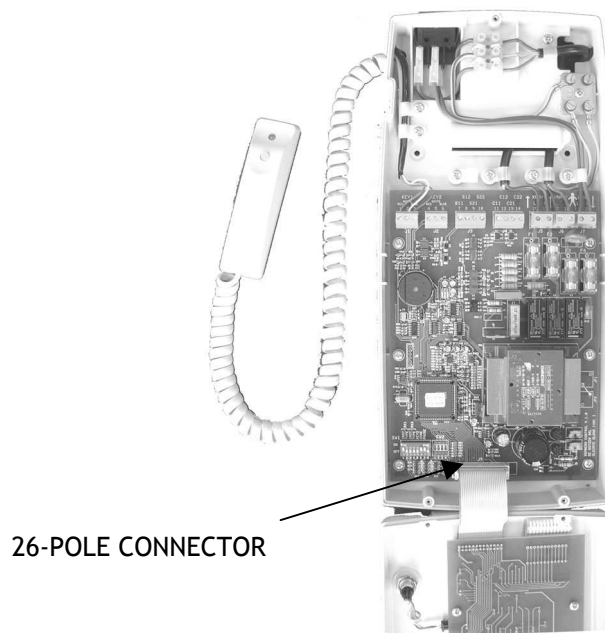
### ASSEMBLY INSTRUCTIONS (Fig. 20)

1. Take the timer out of the packaging (refer to Fig. 5)
2. Take out the drilling template ①
3. Mark the anchor holes on the wall using the drilling template
4. Drill using a  $\varnothing 3\text{mm}$  bit, then drill again with a  $\varnothing 6\text{ mm}$  bit to prevent any flaking of the white coat
5. Insert the three screw anchors provided into the holes ②
6. Open the timer by unscrewing the three screws ③

Fig. 20

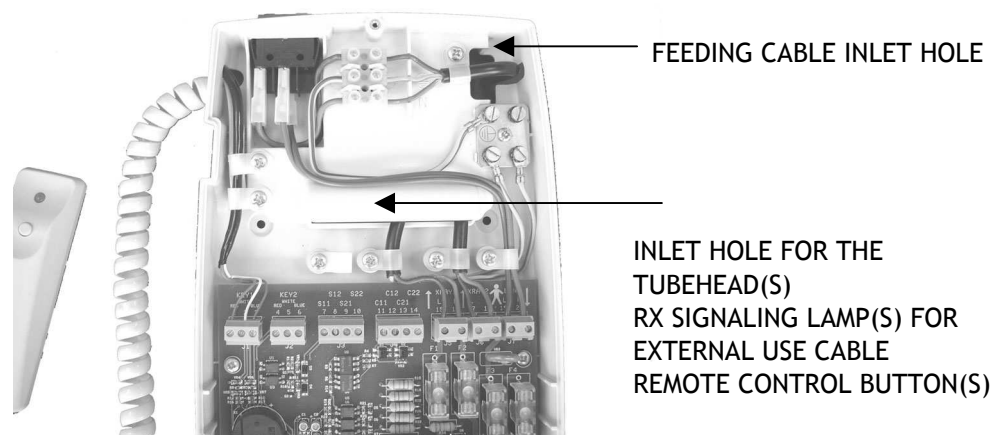


7. Withdraw the 26-pole connector from its seat to release both timer guards (*Fig. 21*)



*Fig. 21*

8. Insert the electrical feeding cables into the hole (*Fig. 22*)



*Fig. 22*

9. Insert the connection cables coming from the tubeheads into the rectangular slot
10. Insert the cables of the RX signaling lamp for external use (IF INSTALLED) (*Fig. 22*)
11. Insert the cables of the remote control button (IF INSTALLED) (*Fig. 22*)
12. Apply the timer base to the wall, matching the three anchor screws with the holes
13. Insert and tighten the screws (*refer to Fig. 20 ④*) with the appropriate washers (*refer to Fig. 20 ⑤*) into the screw anchors

**PLEASE NOTE**

If the wall is uneven, insert some shims to prevent the timer from buckling.

**PLEASE NOTE**

Do not contaminate the timer with dust or rubble from drilling.

## 5.9 TIMER ELECTRIC CONNECTION



### CAUTION

**Before proceeding with connections, the power supply must be cut off.**



### CAUTION

**If the equipment is mounted on metal walls, these must be connected to the grounding circuit.**



### WARNING

**While performing the connection, always comply with the PHASE - NEUTRAL polarity.**



### WARNING

**While stripping the cables, be careful that small copper wires do not fall on the printed circuit and cause short circuits or malfunctioning.**

### OPERATING INSTRUCTIONS (Fig. 23) (refer to §19 “ATTACHMENTS”)

1. Connect the power supply cable to the terminal board ⑥
2. Insert the three mains cables into the rack
3. Fix them with the cable clamp ⑦
4. Connect the cables coming from tubehead n° 1 to the terminals XRAY1
5. Connect the YELLOW-GREEN grounding cable to the “equipotential metal plate” ⑧
6. Connect the cables coming from tubehead n° 2 to terminals XRAY2
7. Connect the YELLOW-GREEN grounding cable to the “equipotential metal plate” ⑧
8. Clamp the cables in the cable clamp ⑨
9. Connect the RX signaling lamps for external use (IF INSTALLED) (refer to §19 “ATTACHMENTS”)
10. Connect the remote control buttons (IF INSTALLED) (refer to §19 “ATTACHMENTS”)
11. Check the configuration on the dip switches (refer to §7 “SYSTEM CONFIGURATION”)
12. Reconnect the 26-pole connector
13. Close the timer with the three screws
14. Mount the wall plate sliding cover and plug (refer to Fig. 6 ③ ⑤)
15. Reconnect the power supply





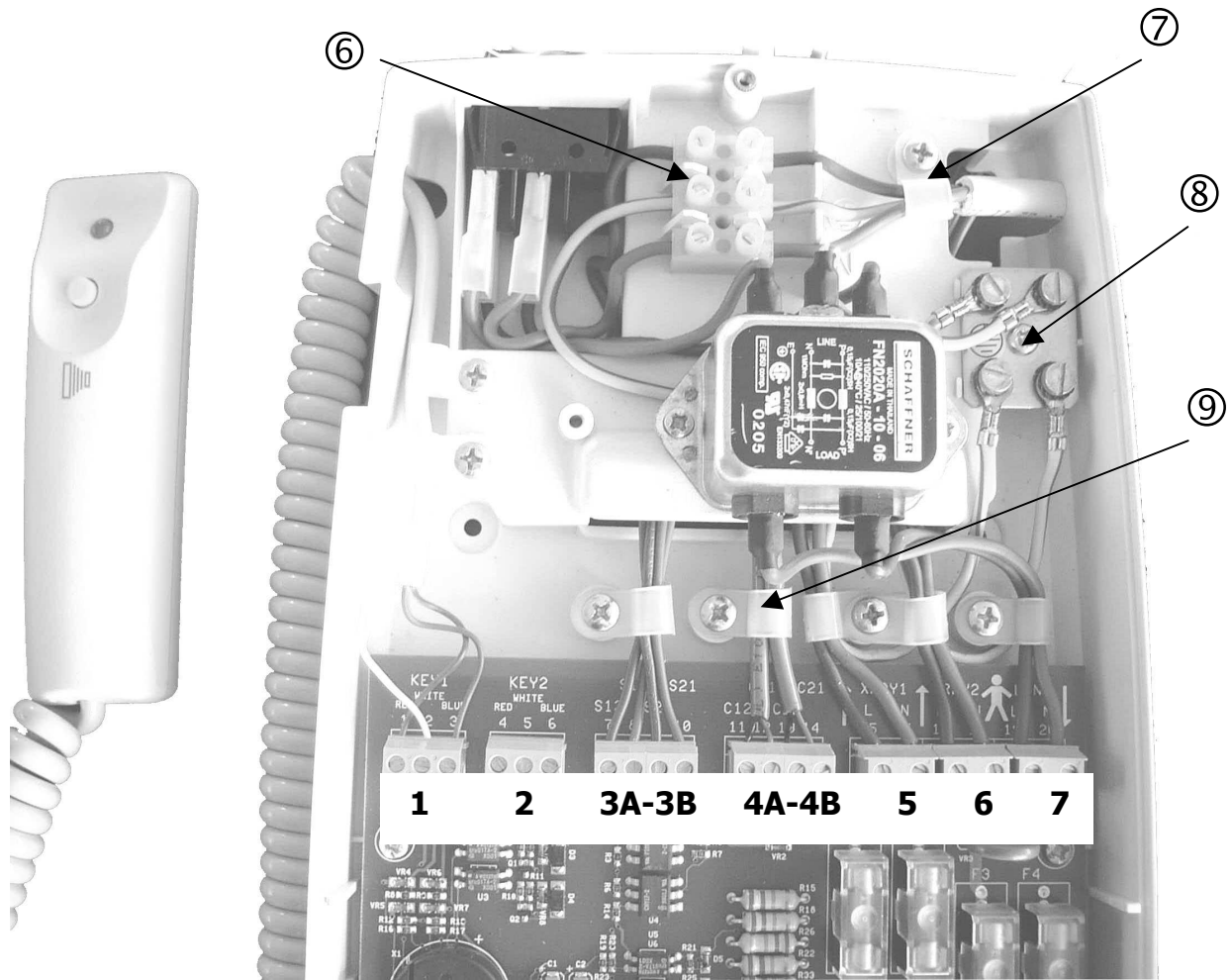


Fig. 23

The electronic card terminal boards control the following functions:

- |    |    |   |
|----|----|---|
| 1  | 1  | TUBEHEAD N° 1 CONTROL BUTTON and/or REMOTE CONTROL BUTTON |
| 2  | 2  | TUBEHEAD N° 2 CONTROL BUTTON and/or REMOTE CONTROL BUTTON |
| 3A | 3A | TUBEHEAD N° 1 RX SIGNALING LAMP FOR EXTERNAL USE          |
| 3B | 3B | TUBEHEAD N° 2 RX SIGNALING LAMP FOR EXTERNAL USE          |
| 4A | 4A | RS232 COMMUNICATION FOR XRAY1                             |
| 4B | 4B | RS232 COMMUNICATION FOR XRAY2                             |
| 5  | 5  | TUBEHEAD N° 1 POWER SUPPLY                                |
| 6  | 6  | TUBEHEAD N° 2 POWER SUPPLY                                |
| 7  | 7  | TIMER POWER SUPPLY  |

## 6. CONTROL PANEL

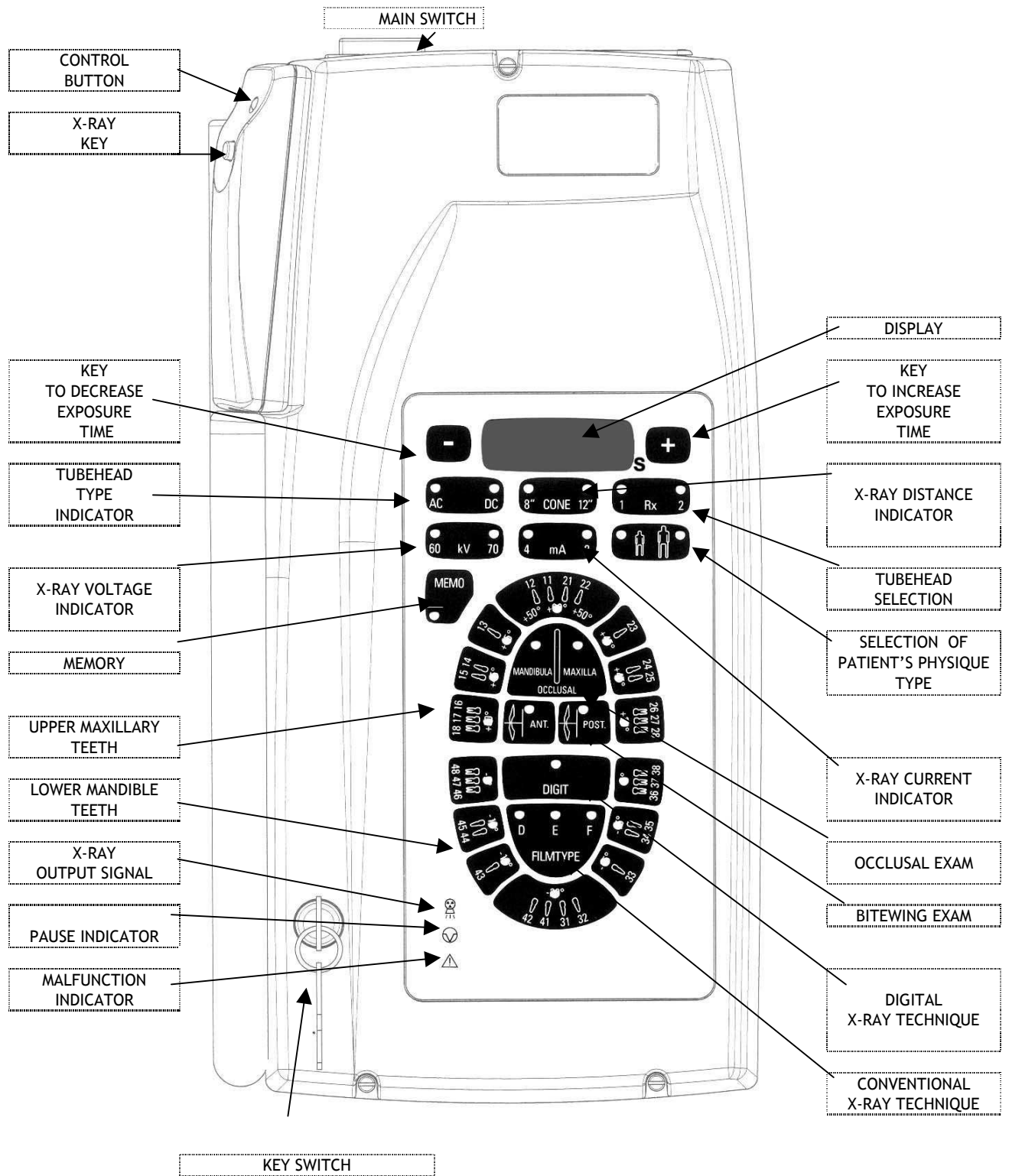
The control panel is the user's interface, from which the operator can:

use the keys

- ➔ to select the operating parameters
- ➔ to change the exposure times displayed
- ➔ to store the new customized exposure times





use the “green LED” light indicators

- ➔ to check the timer operating conditions



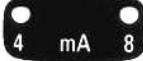



## 7. SYSTEM CONFIGURATION

The “ X-Mind®DC ” X-ray system is factory configured for “standard mode” operation which determines:

No. 2 “ X-Mind®DC ” tube heads	⇒	pressing the RX button  on the control panel causes the LED 1 button to light up, pressing the button again causes the LED 2 to light up
<b>** IF THE LONG 12” (31 cm) CONE IS USED **</b>		
An X-ray distance SSD = 31cm with the long 12” cone	⇒	on the control panel  LED 12” is lit
<b>** IF THE SHORT 8” (20 cm) CONE IS USED **</b>		
An X-ray distance SSD = 20cm with the short 8” cone	⇒	on the control panel  8” LED is lit
with film type “D”	⇒	on the control panel  “D” LED is lit
no. 1 CONTROL BUTTON to make the exposure	⇒	The timer includes a key with an extension cable

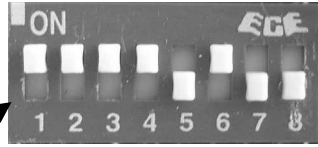
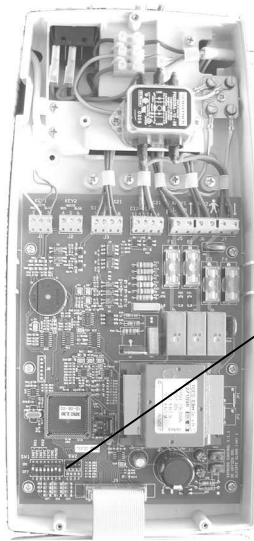
The installed tube head has the following features:

work with direct current at constant potential		the “DC” LED on the control panel must be lit
work with an X-ray voltage equal to 70kVp		the “70 kVp” LED on the control panel must be lit
work with an X-ray current equal to 8mA		the “8 mA” LED on the control panel must be lit

The above configuration depends on the position of 8 mini-switches (dip-switch  ) on the timer electronic card:

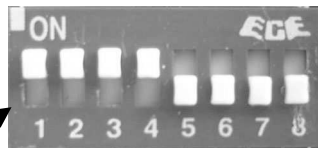
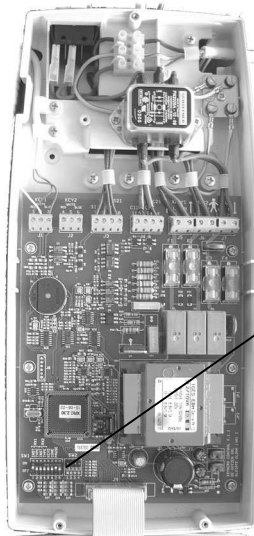
DIP SWICH	PARAMETER	ON	OFF
1	TUBEHEAD No. 1	INSTALLED	NOT INSTALLED
2	TYPE OF TUBEHEAD No. 1	<b>dc</b> DIRECT CURRENT AT CONSTANT POTENTIAL	<b>ac</b> ALTERNATING CURRENT SINGLE-PHASE
3	TUBEHEAD No. 2	INSTALLED	NOT INSTALLED
4	TYPE OF TUBEHEAD No. 2	<b>dc</b> DIRECT CURRENT AT CONSTANT POTENTIAL	<b>ac</b> ALTERNATING CURRENT SINGLE-PHASE
5	CONTROL BUTTON No. 2	INSTALLED	NOT INSTALLED
6	CONE	LONG (12”)	SHORT (8”)
7	NOT AVAILABLE	NOT AVAILABLE	
8	NOT AVAILABLE	NOT AVAILABLE	

**\*\* IF THE LONG 12" (31 cm) CONE IS USED \*\***



	ON	OFF	
1	■		tubehead no. 1
2	■		"dc" type tubehead
3	■		tube head .no. 2
4	■		"dc" type tubehead
5		■	control button no. 2
6	■		12" cone (31cm)
7		■	not available
8		■	not available

**\*\* IF THE SHORT 8" (20 cm) CONE IS USED \*\***



	ON	OFF	
1	■		no. 1 tubehead
2	■		"dc type" tubehead
3	■		no. 2 tubehead
4	■		"dc" type tubehead
5		■	no. 2 control button
6		■	8" cone (20 cm)
7		■	not available
8		■	not available

The configuration may be changed if:

POSSIBLE MODIFICATION	HOW TO CARRY OUT THE MODIFICATIONS
<ul style="list-style-type: none"> <li>- type "E" and "F" films are used</li> <li>- a digital system is used</li> <li>- use of a voltage equal to 60 kV</li> <li>- use of a current equal to 4 mA</li> </ul>	<p style="text-align: center;">refer to <i>USER'S MANUAL</i> § 6 "<i>OPERATING INSTRUCTIONS</i>"</p>
<ul style="list-style-type: none"> <li>- the short 8" (20 cm) cone is used</li> <li>- the long 12" (31 cm) cone is used</li> <li>- a single tubehead is used</li> <li>- use of a tubehead with "ac" technology</li> <li>- no. 2 CONTROL BUTTON is used</li> </ul>	<p style="text-align: center;">by changing the dip switch position <small>THIS MAY ONLY BE DONE BY THE INSTALLER</small></p>

## 8. CHANGING THE CONFIGURATION



### CAUTION

*This must be done by the installer.*



### WARNING

*To make the changes operative, turn off the timer and then turn it on again.*



To change the configuration, the timer's dip switch positions (1 2 3 4 5 6 7 8) must be changed:

DIP SWICH	PARAMETER	ON	OFF
1	TUBEHEAD No. 1	INSTALLED	NOT INSTALLED
2	TYPE OF TUBEHEAD No. 1	<b>dc</b> DIRECT CURRENT AT CONSTANT POTENTIAL	<b>ac</b> ALTERNATING CURRENT SINGLE-PHASE
3	TUBEHEAD No. 2	INSTALLED	NOT INSTALLED
4	TYPE OF TUBEHEAD No. 2	<b>dc</b> DIRECT CURRENT AT CONSTANT POTENTIAL	<b>ac</b> ALTERNATING CURRENT SINGLE-PHASE
5	No. 2 CONTROL BUTTON	INSTALLED	NOT INSTALLED
6	CONE	LONG (12")	SHORT (8")
7	NOT AVAILABLE	NOT AVAILABLE	
8	NOT AVAILABLE	NOT AVAILABLE	

## 1. CHANGING THE NUMBER OF TUBEHEADS INSTALLED

To change the number of tubeheads installed, move dip switch no. 1 or no. 3

- a. If the tubehead is connected to the X-RAY 1 terminal board, put dipswitch no. 1 in the ON position; if not, put it in the OFF position
- b. If the tubehead is connected to the X-RAY 2 terminal board, put dip switch no. 3 in the ON position; if not, put it in the OFF position

## 2. CHANGING THE TYPE OF TUBE HEAD

The following timer connections may be made:

no. 2 TUBEHEADS USING ALTERNATING CURRENT “ac”: “X-Mind® AC”

or

no. 2 TUBEHEADS USING DIRECT CURRENT “dc”: “X-Mind® DC”

or

no. 1 TUBEHEAD USING ALTERNATING CURRENT “ac” + no. 1 TUBE HEAD USING DIRECT CURRENT “dc”: “X-Mind® AC” + “X-Mind® DC”

To change the type of tubehead, move dip switch no. 2 or no. 4

- a. If tubehead RX1 is “ac”, put dip-switch no. 2 in the OFF position, otherwise put it in the ON position
- b. If tub head RX2 is “ac”, put dip-switch no. 4 in the OFF position, otherwise put it in the ON position

## 3. CHANGING THE CONE

To replace the long 12” cone with the short 8” cone, move dip switch no. 6 to the OFF position.

Check that the “8” LED lights up on the control panel.

### PLEASE NOTE

After modification, the set exposure times are automatically changed.

To replace the short 8” cone with the long 12” cone, move dip switch no. 6 to the ON position.

Check that the “12” LED lights up on the control panel.

### PLEASE NOTE

After modification, the set exposure times are automatically changed.

## 4. CHANGING THE REMOTE BUTTONS SETTINGS

To change the control buttons settings, move dip switch no. 5 to the ON position.

### PLEASE NOTE

After modification, each tube head is controlled by its button.

## 9. START UP

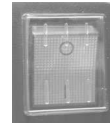


### CAUTION

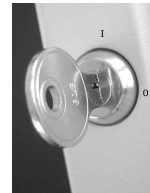
*When all connections are completed, the installer must check the system's electrical and operating safety.  
For further information, see the USER'S MANUAL.*

TURN ON THE TIMER to power up the X-ray system

- a. Bring the "MAIN SWITCH" located on the upper part of the timer to the "I" position (ON)



- b. Bring the "KEY SWITCH" to the "I" position (ON)




- ➡ the green light turns on indicating that the system is powered up
- ➡ the LEDs of the set parameters automatically light up
- ➡ the exposure time is shown on the display

- c. THE X-RAY SYSTEM IS NOW READY FOR USE



### WARNING

*If an error is detected when the system is turned on, the anomaly is indicated as follows:*

- *an intermittent beep sounds*
- *the MALFUNCTION INDICATOR LED  blinks intermittently*  
*The error code (E ...) appears on the display*  
*(refer to § 13 "ERROR MESSAGES")*
- *All control panel functions are disabled*

*In this event, turn off the timer and then turn it back on.  
If the error should recur, call the "Support Department".*

### PLEASE NOTE

The exposure time and parameters displayed are the last which to be set before the timer was turned off.

### PLEASE NOTE

If installed, the RX signal lamp for external use, corresponding to the selected tube head, turns on.

### PLEASE NOTE

If the timer remains inactive for a few minutes, it switches to the stand-by mode.  
Press any control panel key to restore it to operating mode.



## 10. CHECKING THE INSTALLATION

### OPERATING INSTRUCTIONS

#### 1. CHECKING THE CONFIGURATION




On the control panel, check that all LEDs corresponding to the required configuration are lit; if not, change them.

(refer to § 7 “SYSTEM CONFIGURATION” and § 8 “CHANGING THE CONFIGURATION” )

#### 2. CHECKING THE TIMER OPERATION

- a. Check the correct operation of the control panel by selecting different exposure times
- b. Check the time on the display
- c. Check that, when changing the selected tube head, the corresponding RX signal lamp for external use (IF INSTALLED) turns on

#### 3. CHECKING THE EXPOSURE

- a. Set an exposure time of 1 sec
- b. Take the timer’s “CONTROL BUTTON”
- c. Using the extension cable of the “CONTROL BUTTON”, maintain a safe distance of at least 2 meters from the tube head, so as to be able to constantly check the X-ray exposure
- d. Press the “X-RAY”  key and keep it depressed until the acoustic signal (beep) stops, and the yellow X-RAY OUTPUT SIGNAL  LED turns off
- e. At the end of the exposure, the green PAUSE INDICATOR  LED blinks intermittently
- f. On the display, check the actual exposure time  
(refer to § 11 4. “EXPOSURE TIME (sec)” )

#### 4. CHECKING THE TUBEHEAD OPERATION

Take several exposures on the tubehead installed and check that:

- a. There are no errors
- b. The LED of the selected tube head is lit
- c. The “CONTROL BUTTON” LED is lit for the entire duration of the acoustic signal

## 5. CHECKING THE POWER ABSORBED BY THE X-RAY SYSTEM

To check the power absorbed by the radiographic system a tester must be used, in the mode ampmeter in “AC”

- a. Connect the instrument to the power supply line  
(refer to § 5.9 “TIMER ELECTRIC CONNECTION”)
- b. Set an exposure time of approx. 3 sec on the timer
- c. Take an exposure and read the current value on the display

### PLEASE NOTE

The X-ray system complies with the requirements when

the absorbed current is  $\leq 8A$  with 230V line voltage ( $\pm 15\%$ )

the absorbed current is  $\leq 12.5A$  with 115V line voltage ( $\pm 15\%$ )

Otherwise, check the electrical system or call the “Support Department”.

## 6. CHECKING THE ELECTRIC SYSTEM

To check the electric system, a tester must be used, in the mode voltmeter in “AC”

- a. Connect the instrument to the L and N terminals on the timer
- b. Measure the line voltage ( $V_0$ )
- c. Connect the instrument to the L and N terminals of the wall plate terminal board  
(refer to § 5.5 “CONNECTION TO THE FEEDING TERMINAL BOARD”)
- d. Set an exposure time of approx. 3 sec on the timer
- e. Proceed with the exposure
- f. Measure the line voltage during exposure ( $V_1$ )

### PLEASE NOTE

The electrical system complies with the requirements when the result of the formula

$$(V_0 - V_1) / V_0 \text{ is } \leq 0.03 (3\%)$$

Otherwise, the electric system must be adjusted.  
(refer to § 4 “INSTALLATION SPECIFICATIONS”)

## 11. CHECKING THE EXPOSURE FACTORS

### OPERATING INSTRUCTIONS

#### 1. RADIOGRAPHIC VOLTAGE (kVp)

The radiographic high voltage is measured using a calibrated "non-invasive" instrument with an initial delay of 50 m. sec.

SET TECHNICAL VALUES	Line Voltage = nominal V $\pm 15\%$ Max Voltage Drop = 3 % kVp = 60 - 70 mA = 4 - 8 Set Exposure Time = 3.2 sec
-------------------------	---

The radiographic VOLTAGE is 60 kVp - 70 kVp  $\pm 10\%$

#### 2. RADIOGRAPHIC CURRENT (mA)

The radiographic current is measured by connecting a milliammeter inside the tube head

SET TECHNICAL VALUES	Line Voltage = Nominal V $\pm 15\%$ Max Voltage Drop = 3 % kVp = 60 - 70 mA = 4 - 8 Set Exposure Time = 3.2 sec
-------------------------	---

The radiographic CURRENT is 4mA - 8mA  $\pm 10\%$

#### 3. DOSE (mGy)

The dose in the air is measured with a "non-invasive" instrument, by positioning the detector at an SSD (source-skin distance) of 31 cm (12") or 20 cm (8")

SET TECHNICAL VALUES	Line Voltage = Nominal V $\pm 15\%$ Max Voltage Drop = 3 % kVp = 60 - 70 mA = 4 - 8 Set Exposure Time = 1 sec
-------------------------	---

DOSE in the air =

<u>SSD = SOURCE-SKIN DISTANCE = 31 CM (12")</u>	<u>SSD = SOURCE-SKIN DISTANCE = 20 CM (8")</u>
70 kVp - 8 mA = 5.5 mGy/s $\pm 30\%$	70 kVp - 8 mA = 12 mGy/s $\pm 30\%$
60 kVp - 8 mA = 4.5 mGy/s $\pm 30\%$	60 kVp - 8 mA = 9 mGy/s $\pm 30\%$
70 kVp - 4 mA = 3 mGy/s $\pm 30\%$	70 kVp - 4 mA = 6 mGy/s $\pm 30\%$
60 kVp - 4 mA = 2.2 mGy/s $\pm 30\%$	60 kVp - 4 mA = 4.5 mGy/s $\pm 30\%$

#### 4. EXPOSURE TIME (sec)

The exposure time is measured with a "non-invasive" instrument.





SET TECHNICAL VALUES	Line Voltage = Nominal V $\pm 15\%$ Max Voltage Drop = 3 % kVp = 60 - 70 mA = 4 - 8 Set Exposure Time = 3.2 sec
-------------------------	---

The EXPOSURE TIME measured is 3.2 sec  $\pm 10\%$

## 12. DIAGNOSTIC

The “X-Mind® DC” X-ray system allows the installer to set or display some of the timer’s functional parameters:

1. To set the parameters, the installer must:






- a. Turn off the timer
- b. Simultaneously press and keep the following keys depressed:  
(45) LOWER MANDIBLE PREMOLAR + (43) LOWER MANDIBLE CANINE
- c. Turn on the timer
- d. When the message “inst” is displayed, the installer can set the minimum exposure time:
  1. select the tube head
  2. turn off the timer
  3. turn on the timer, by keeping the  key depressed
  4. the message “SEC” is displayed for approx 1 sec
  5. the current value of the lower set limit is displayed
  6. to change the value, press the keys  and 
  7. to confirm, press the  key
- e. To exit this mode, turn the timer off and then on again



2. To display the parameters, the installer must:

- a. Simultaneously press and keep depressed the  
(17) UPPER MAXILLARY MOLAR + (47) LOWER MAXILLARY MOLAR keys
- b. Press the key associated with the desired parameter



KEY		DISPLAYED PARAMETER	Example	U.M.
	<b>BITEWING ANT</b>	X-RAY SYSTEM NOMINAL VOLTAGE	230	Volt
	<b>BITEWING POST</b>	LINE VOLTAGE	227	Volt
	<b>UPPER INCISOR</b>	MAXIMUM LINE VOLTAGE VALUE DETECTED	238	Volt
	<b>LOWER INCISOR</b>	MINIMUM LINE VOLTAGE VALUE DETECTED	215	Volt
	<b>OCCLUSAL</b>	SOFTWARE VERSION	2.3	

## 13. CALIBRATION



### CAUTION


*During this operation there is X-ray output.*

*All the safety measures relevant to radioprotection must be observed.*

If necessary, “ X-Mind® DC ” can be calibrated.

The relevant procedure is as follows:


a. Switch off the timer


b. Switch on the timer and keep the mA  button depressed

c. The display shows the “tube” message

d. Select X-RAY with the  button to calibrate

e. Take the exposure:

Press and keep the “RX”  button depressed until the beeping stops

stops the yellow  “X-RAY OUTPUT SIGNAL” LED goes off

f. Once the exposure has been taken, if the display does not show “ERRORS”, the calibration has been successfully completed, otherwise (*refer to §14 “ERROR MESSAGES”*)

## 14. ERROR MESSAGES

The following chart contains a list of error messages that may appear while the “X-Mind® DC” X-ray system is operating.

The chart also includes the causes of the error messages and what to do to resolve them.

Error Message	Cause	Solution
E00	RX1 TUBE HEAD IS NOT CONNECTED OR IS OUT OF ORDER	CALL THE “SUPPORT DEPARTMENT”
E01	RX2 TUBE HEAD IS NOT CONNECTED OR IS OUT OF ORDER	CALL THE “SUPPORT DEPARTMENT”
E02	CORRUPTED EEPROM DATA	CALL THE “SUPPORT DEPARTMENT”
E03	EEPROM DATA NOT PROPERLY SAVED	CALL THE “SUPPORT DEPARTMENT”
E05	LINE VOLTAGE VALUE NOT WITHIN THE SET LIMITS	CALL THE “SUPPORT DEPARTMENT”
E07	LINE VOLTAGE VALUE NOT INCLUDED WITHIN THE $\pm 15\%$ NOMINAL VALUE	CALL THE “SUPPORT DEPARTMENT”
E08	THE “X-RAY” KEY ALWAYS SEEMS TO BE DEPRESSED	ENSURE THAT IT IS NOT JAMMED
E09	ANOMALY ON THE CONTROL PANEL	CALL THE “SUPPORT DEPARTMENT”
E12	THE EXPOSURE HAS BEEN PREMATURELY INTERRUPTED	KEEP THE “X-RAY KEY” DEPRESSED TILL THE END OF THE EXPOSURE
E20	ANOMALY IN THE TRIAC/RELAY	CALL THE “SUPPORT DEPARTMENT”
E21	ANOMALY IN THE ELECTRONIC CIRCUIT	CALL THE “SUPPORT DEPARTMENT”
E22	ANOMALY IN THE CONTROL CIRCUIT	CALL THE “SUPPORT DEPARTMENT”
E23	INCORRECT DIP SWITCH CONFIGURATION	CALL THE “SUPPORT DEPARTMENT”
E24	THE “CONTROL BUTTON” DOES NOT CORRESPOND TO THE SELECTED TUBE HEAD	USE THE “CONTROL BUTTON” THAT CORRESPONDS TO THE SELECTED TUBE HEAD
E30	THE TUBEHEAD DOES NOT WORK PROPERLY	CALL THE “SUPPORT DEPARTMENT”
E32	THE TUBEHEAD IS NOT IN THE CORRECT MODE	CALL THE “SUPPORT DEPARTMENT”

E33	THE TUB HEAD HAS NOT COMPLETED THE EXPOSURE	REPEAT THE EXPOSURE OR CALL THE "SUPPORT DEPARTMENT"
E40	FREQUENCY OR REGULATION PROBLEM	CALL THE "SUPPORT DEPARTMENT"
E41	THE TUBEHEAD IS NOT CALIBRATED	CALIBRATE OR CALL THE "SUPPORT DEPARTMENT"
E42	EEPROM DATA NOT PROPERLY SAVED	CALL THE "SUPPORT DEPARTMENT"
E43	CORRUPTED EEPROM DATA	CALL THE "SUPPORT DEPARTMENT"
E44	OVERVOLTAGE ERROR	CALL THE "SUPPORT DEPARTMENT"
E45	ANODE VOLTAGE OUT OF TOLERANCE	CALL THE "SUPPORT DEPARTMENT"
E46	ANODE CURRENT OUT OF TOLERANCE	CALL THE "SUPPORT DEPARTMENT"
E47	CONTROL CONNECTOR	CALL THE "SUPPORT DEPARTMENT"
E48	REFERENCE VOLTAGE PROBLEM	CALL THE "SUPPORT DEPARTMENT"
Err	MAJOR ERROR	ALL X-RAY SYSTEM FUNCTIONS ARE DISABLED CALL THE "SUPPORT DEPARTMENT"

## 15. FUSE REPLACEMENT

The timer's electronic equipment is protected by 4 fuses located on the electronic card.

To replace them, proceed as follows (Fig. 25):

1. Cut off the power supply
2. Temporarily remove the timer's guard ① by removing the adjusting ②

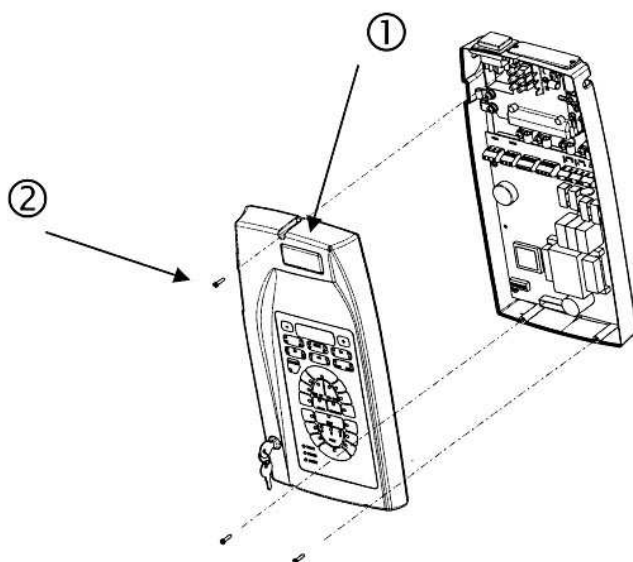


Fig. 25

3. Determine the fuse to be replaced (Fig. 26)
4. Remove the plastic protector (Fig. 27)
5. Remove the fuse
6. Replace it with a fuse of same type

POWER VOLTAGE OF THE X-RAY SYSTEM	230 V $\pm$ 15 %	115 V $\pm$ 15 %
Internal protection fuses (5x20) quick	8AF - 250V	12.5AF - 250V

7. Insert the protection

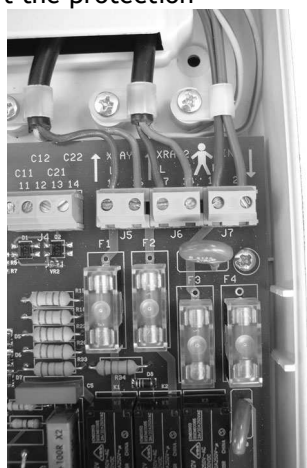


Fig. 26

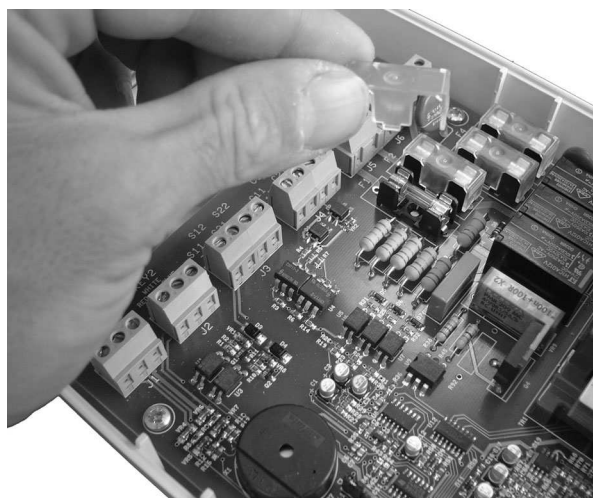


Fig. 27

8. Close the timer's guard
9. Restore the power



## 16. MAINTENANCE

To guarantee the X-ray system's safety, the following checks must be carried out:



### CAUTION

***The owner is responsible for arranging and respecting the maintenance schedule.  
The X-ray system must undergo maintenance to check for correct operation every 12 months.***

1. Cut the power
2. Release the spring of the "ARM B" of the pantograph type arm using the key provided  
(refer to § 5.7 "BALANCING THE PANTOGRAPH-TYPE ARM")
3. Remove the tube head  
(refer to § 5.6 "ASSEMBLING THE TUBE HEAD")
4. Remove the wall plate guard  
(refer to § 5.2 "ASSEMBLING THE WALL PLATE")
5. Remove the terminal board cover and disconnect the pantograph-type arm cable
6. Remove the bracket plug and remove the guard slab  
(refer to § 5.4 "ASSEMBLING THE PANTOGRAPH-TYPE ARM")
7. Remove the pantograph-type arm and its cable from the bracket
8. Remove the bracket from the wall plate  
(refer to § 5.3 "ASSEMBLING THE BRACKET")
9. Check the wall plate's vertical alignment - adjust if required
10. Check the six wall plate's adjusting screws - tighten if required
11. Clean the old lubricating grease from the bracket shaft
12. Should the bracket shaft be damaged, install a new bracket
13. Clean the old lubricating grease from the bracket bush
14. If the bracket bush is damaged, install a new bracket
15. Grease the bracket shaft (use "molikote D" lubricant)
16. Lubricate the bracket bush with lubrication grease (use "molikote D" lubricant)
17. Install the bracket in the wall plate  
(refer to § 5.3 "ASSEMBLING THE BRACKET")
18. Check the pantograph-type arm cable  
If it is be damaged, send the pantograph-type arm to the manufacturer for repairs
19. Check the pantograph-type arm guards
20. Replace the damaged guards
21. Remove all old grease of the shaft  
(refer to §. 5.4 "ASSEMBLING THE PANTOGRAPH-TYPE ARM")
22. If the shaft is damaged, send the pantograph-type arm to the manufacturer for repairs
23. Lubricate the pantograph-type arm shaft with lubricant (use "molikote D" lubricant) and reposition it in the bracket
24. Replace the pantograph-type arm cable in the bracket and the wall plate, connect it to the terminal board and replace the terminal board cover  
(refer to § 5.5 "CONNECTION TO THE TERMINAL BOARD")
25. Position the guard slab in the bracket
26. Position the bracket plug
27. Position the plate guard
28. Check the tubehead's electrical contact
29. If damaged, send the tube head to the manufacturer for repairs
30. Clean the old grease from the tube head assembly shaft
31. Lubricate the tubehead's assembly shaft with a thin layer of lubricant( use "molikote D" lubricant)
32. Reposition the tubehead
33. Load the spring of the pantograph-type arm "ARM B" using the key provided  
(refer to § 5.7 "BALANCING THE PANTOGRAPH-TYPE ARM")
34. Power up and check that the X-ray system is operating correctly

## 17. CLEANING THE OUTER SURFACES

Use a soft cloth with water and soap to clean the outer surfaces.

The spacer cone may be cleaned with cotton wool soaked in surgical alcohol.

## 18. IF A REPAIR BECOMES NECESSARY

In case of a malfunction, send the defective part to (USING THE ORIGINAL PACKAGING):

Satelec® S.A.S.  
Z.I. du Phare  
B.P. 216  
33708 MERIGNAC cedex - France

Tel. +33 (0) 556 34 06 07

Fax +33 (0) 556 34 92 92

E-mail: [info@satelec.com](mailto:info@satelec.com)

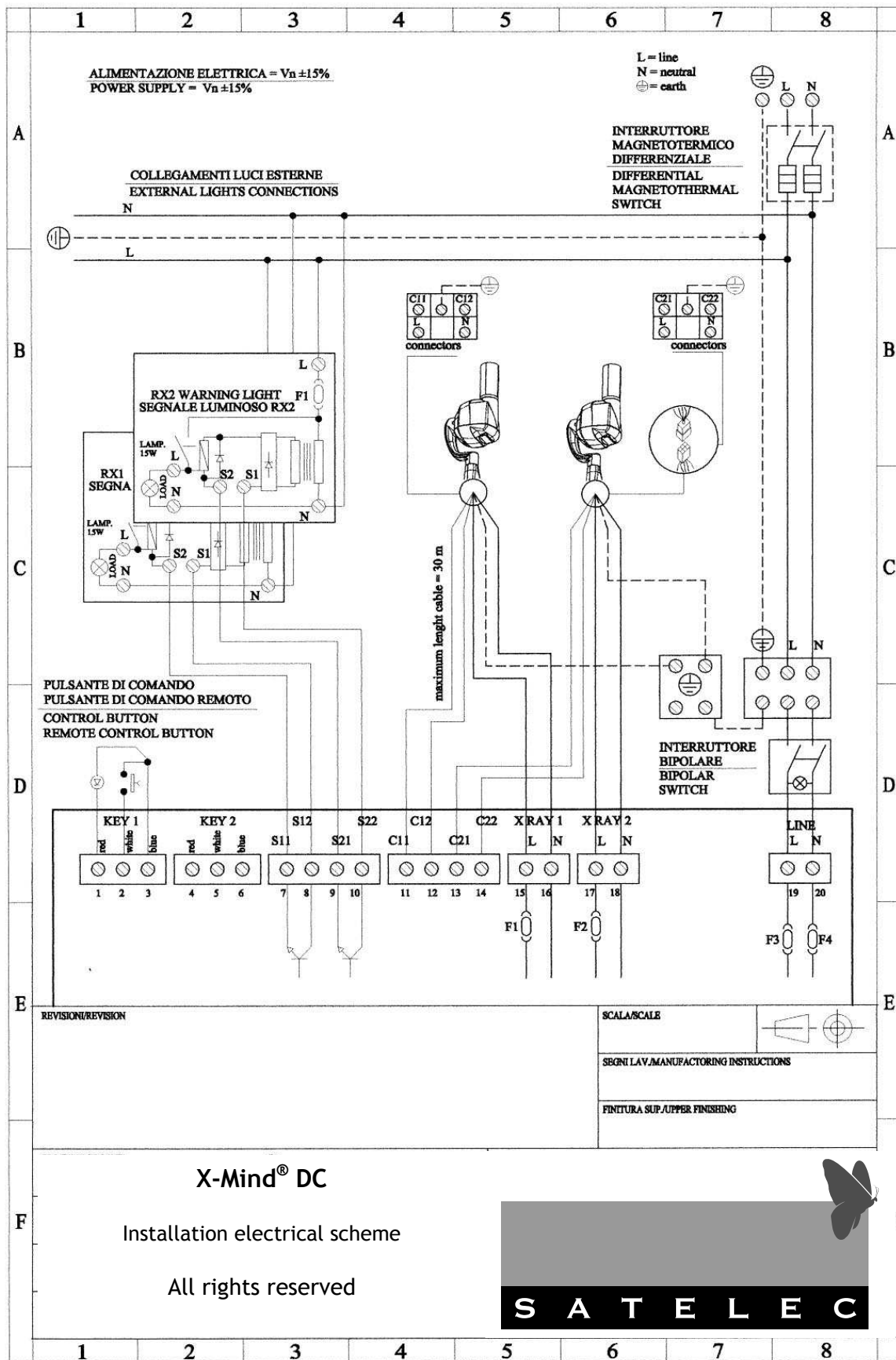
## 19. DISPOSAL

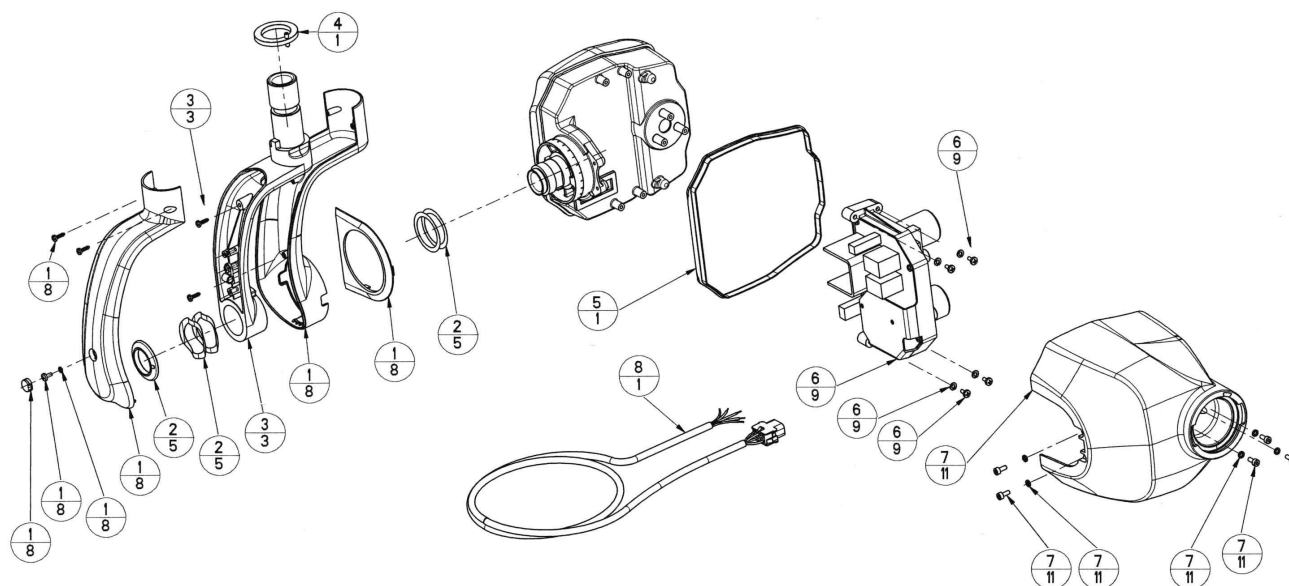
In the event of disposal, the components and packaging must be disposed of in an environmentally correct manner.

In particular, the dielectric oil as well as the shielding lead must be disposed by means of authorized companies specialized in the disposal of waste material.

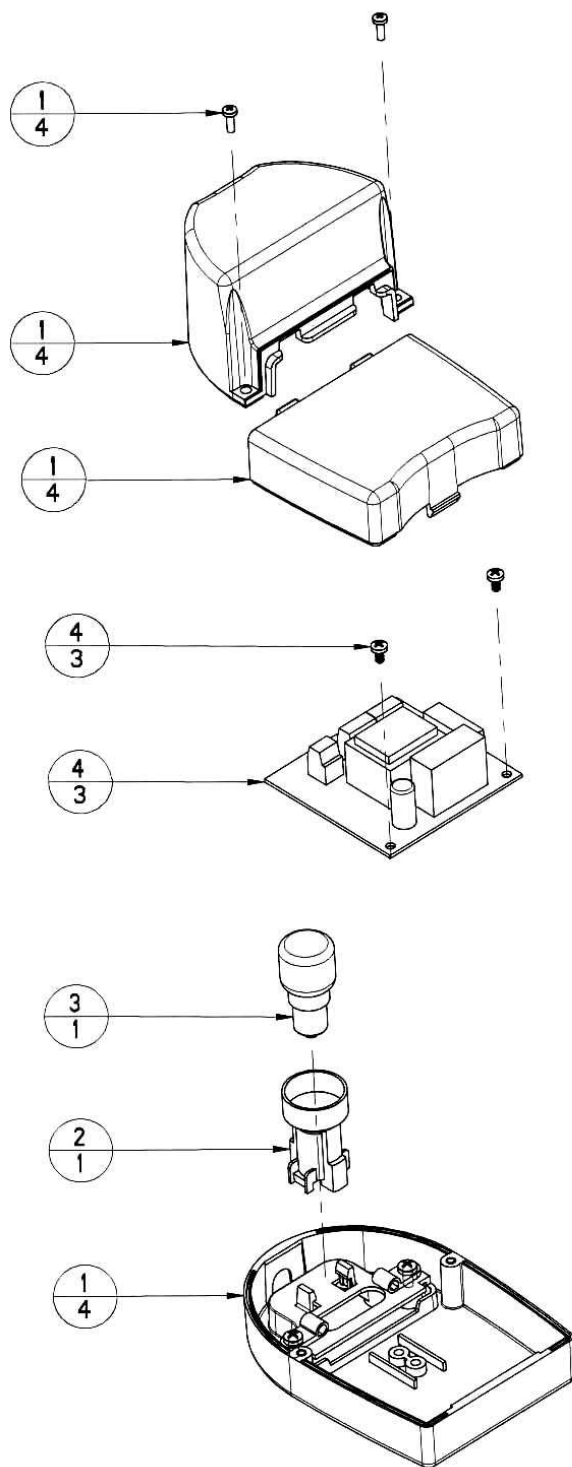
## 20. ACCESSORIES

The manufacturer undertakes to supply, upon request, drawings, circuit diagrams, component parts lists, instructions or other information needed by qualified technical personnel to perform repairs on those parts of the “ X-Mind<sup>®</sup> DC ” radiographic system which may be repaired.

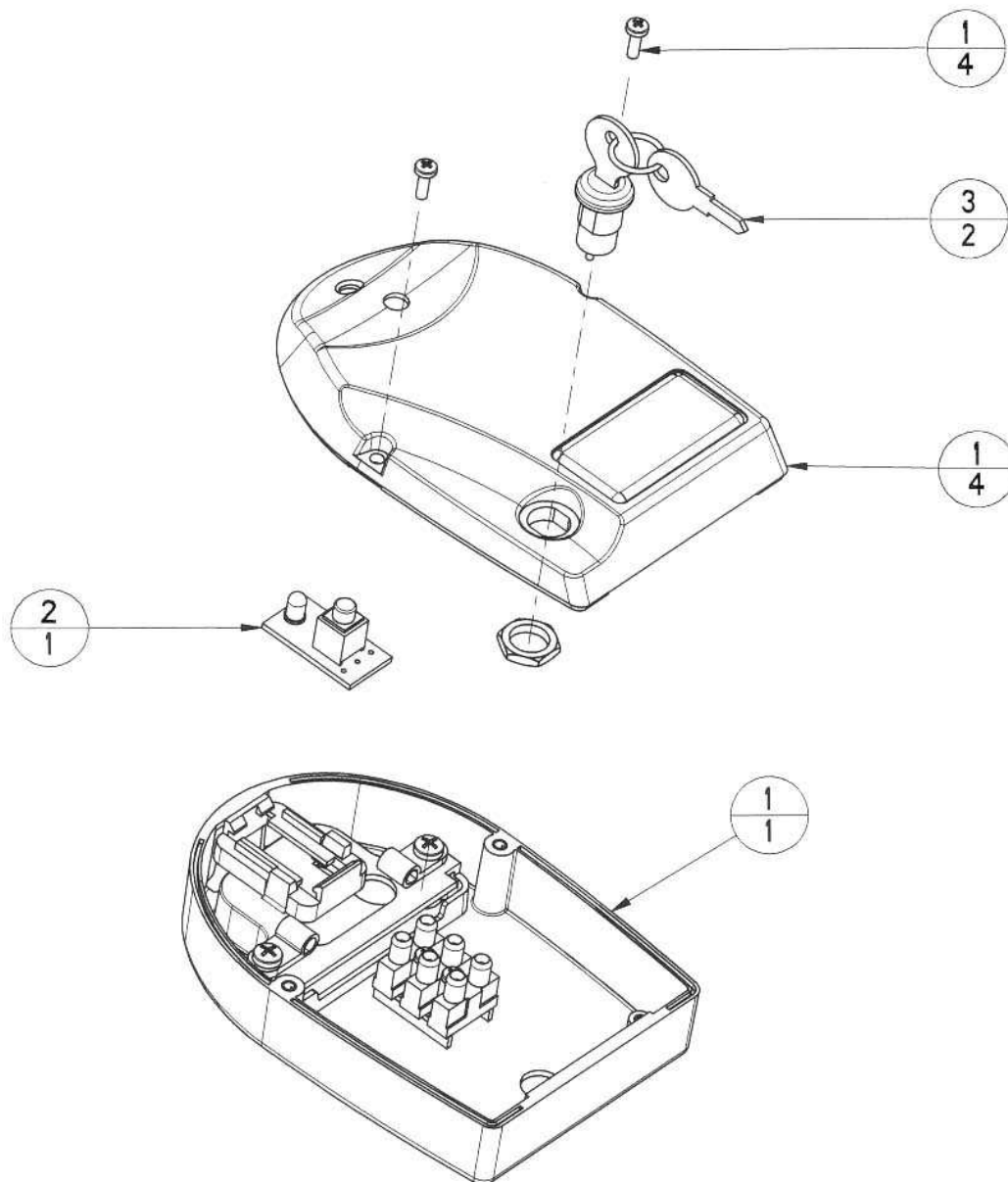




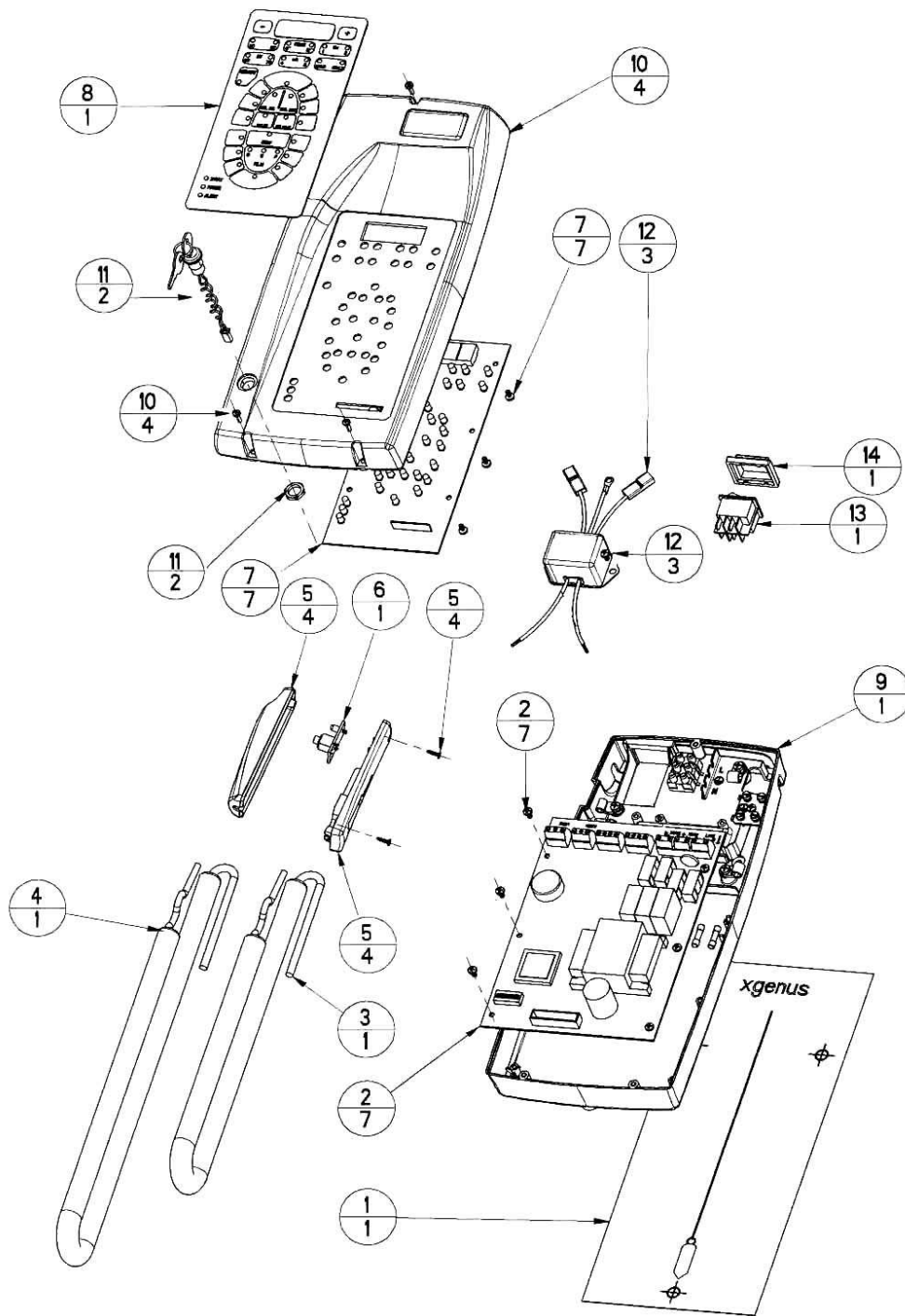
REF	SPARE PARTS TUBE HEAD X-MIND® DC	CODE	Q.TY PCS
1	DC XG (1) COPERTURA FORCELLA	29700979	8
2	AC/DC XG (2) SET GHIERE FORCELLA	29700980	5
3	AC/DC XG (3) FORCELLA	29700777	3
4	AC/DC XG (4) LIMITATORE DI ROTAZIONE	29700750	1
5	DC XG (5) GUARNIZIONE	27500959	1
6	DC XG (6) SCHEDE ARIA	29700981	9
7	DC XG (7) COPERTURA SCHEDA ARIA	29700982	11
8	DC XG (8) CAVO TESTA	39700385	1
A	CONO LUNGO 31cm (12") Ø60	29700397	1
B	CONO CORTO 20cm (8") Ø60	29700396	1
C	CONO QUADRO 31cm (12") 44x35	29700615	1



REF	SPARE PARTS X-MIND® LIGHT	CODE	Q.TY PCS
1	XG LIGHT (1) GUSCIO INF & SUP	29700977	4
2	XG LIGHT (2) PORTALAMPADA	33400372	1
3	XG LIGHT (3) LAMPADINA 230V 15W	33300352	1
3	XG LIGHT (3) LAMPADINA 115V 15W	33300390	1
4	XG LIGHT (4) SCHEDA 230V	39200354	3
4	XG LIGHT (4) SCHEDA 115V	39200353	3

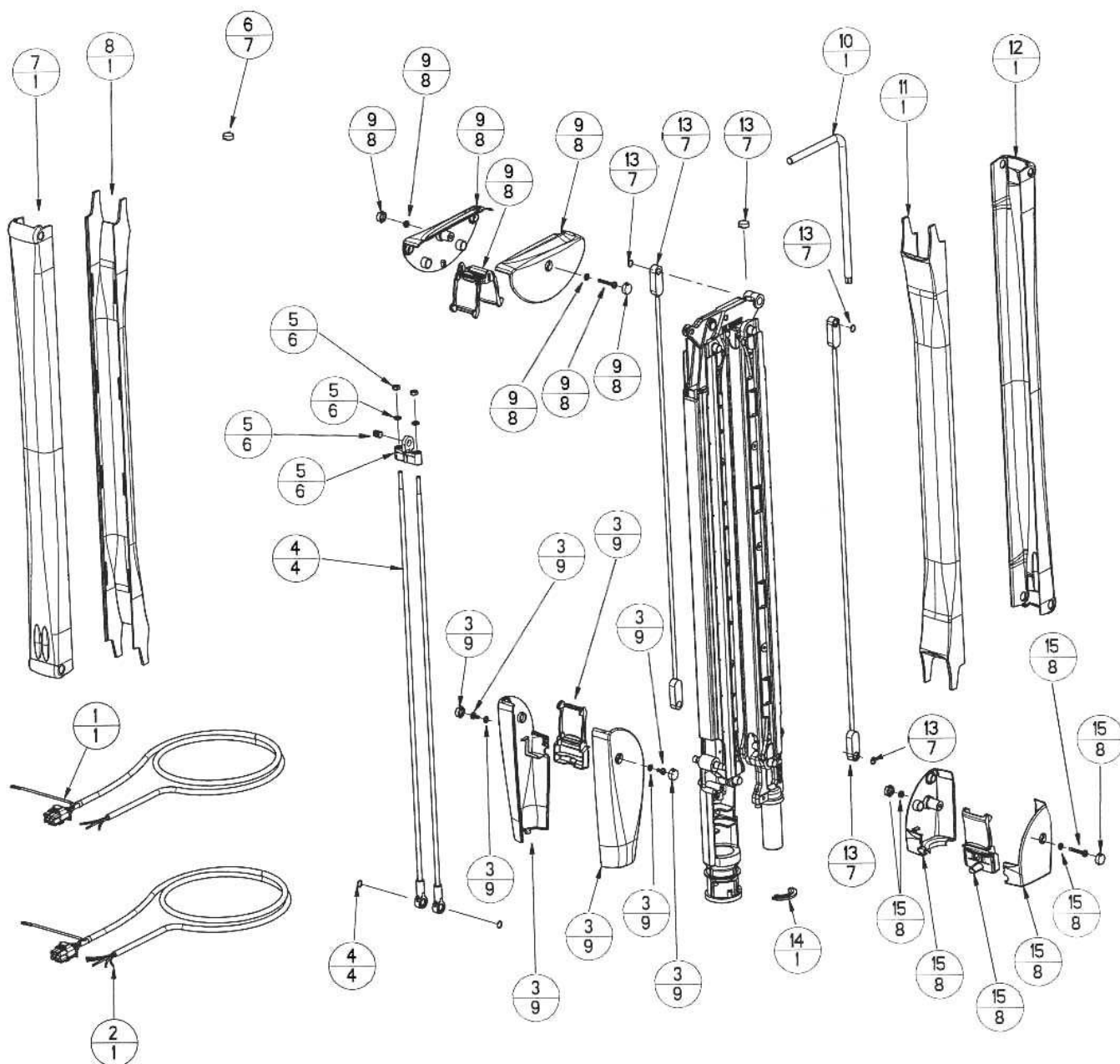


REF	SPARE PARTS X-MIND® ECB	CODE	Q.TY PCS
1	XG ECB (1) GUSCIO INF & SUP	29700978	4
2	SCHEDA COMANDO CON PULSANTE E LED	39700303	1
3	XG ECB (3) INTERRUTTORE A CHIAVE	35100298	1

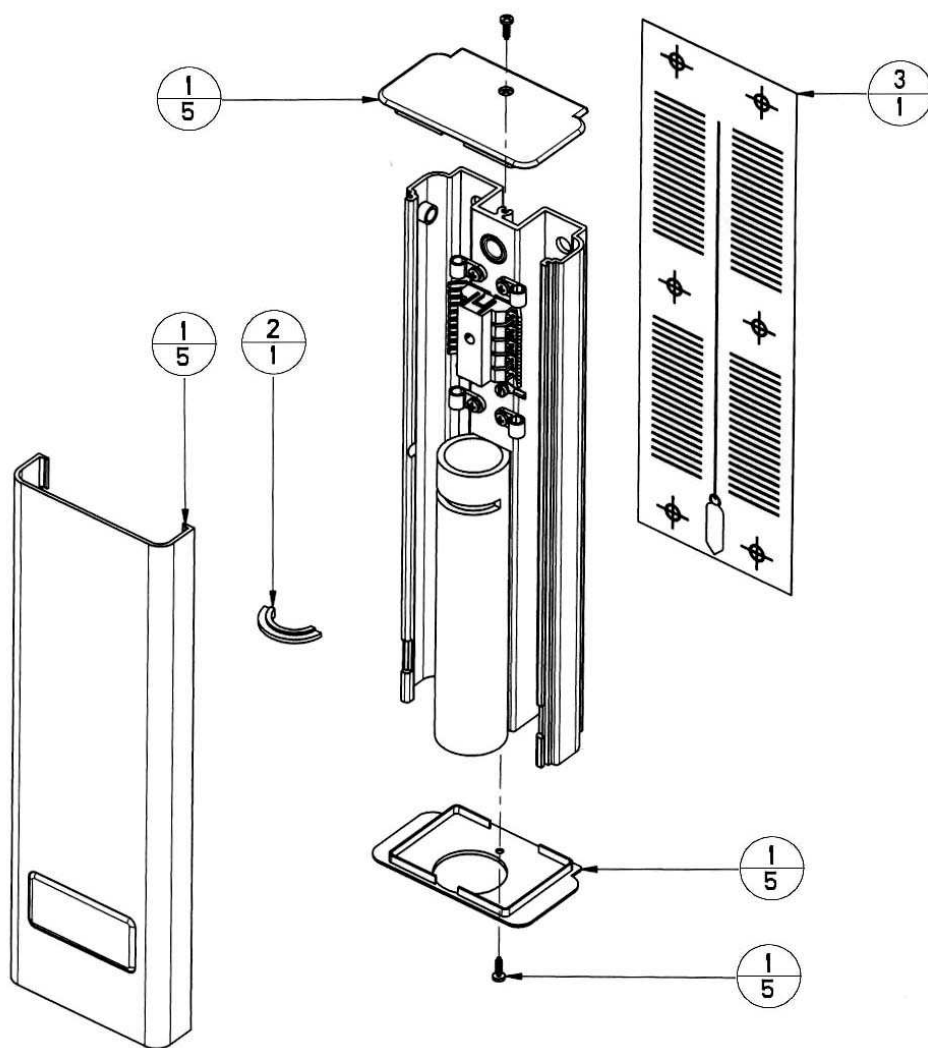


REF	SPARE PARTS TIMER X-MIND®	CODE	Q.TY PCS
1	AC/DC XG TIMER (1) DIMA	24200883	1
2	AC/DC XG TIMER (2) SCHEDA CONTROL	39200306	7
2	AC/DC XG TIMER (2) SCHEDA CONTROL US	39200307	7
3	AC/DC XG TIMER (3) CAVO SPIR	32000325	1
4	AC/DC XG TIMER (4) CAVO SPIR DOPPIO	32000359	1
5	AC/DC XG TIMER (5) CASSA PULSANTE	29700974	4
6	SCHEDA COMANDO CON PULSANTE E LED	39700303	1
7	AC/DC XG TIMER (7) SCHEDA LED	39200313	7
8	AC/DC XG TIMER (8) TASTIERA DEG	39200308	1
8	AC/DC XG TIMER (8) TASTIERA SAT	39200309	1
9	AC/DC XG TIMER (9) CASSA	29700975	1
10	AC/DC XG TIMER (10) COPERCHIO	29700976	4
11	AC/DC XG TIMER (11) BLOCK CHIAVE	39700305	2
12	DC XG TIMER (12) FILTRO	36200382	3
13	INTERRUTTORE BIPOLARE VERDE	35000044	1
14	PROTEZIONE INTERRUTTORE BIPOLARE	33500228	1

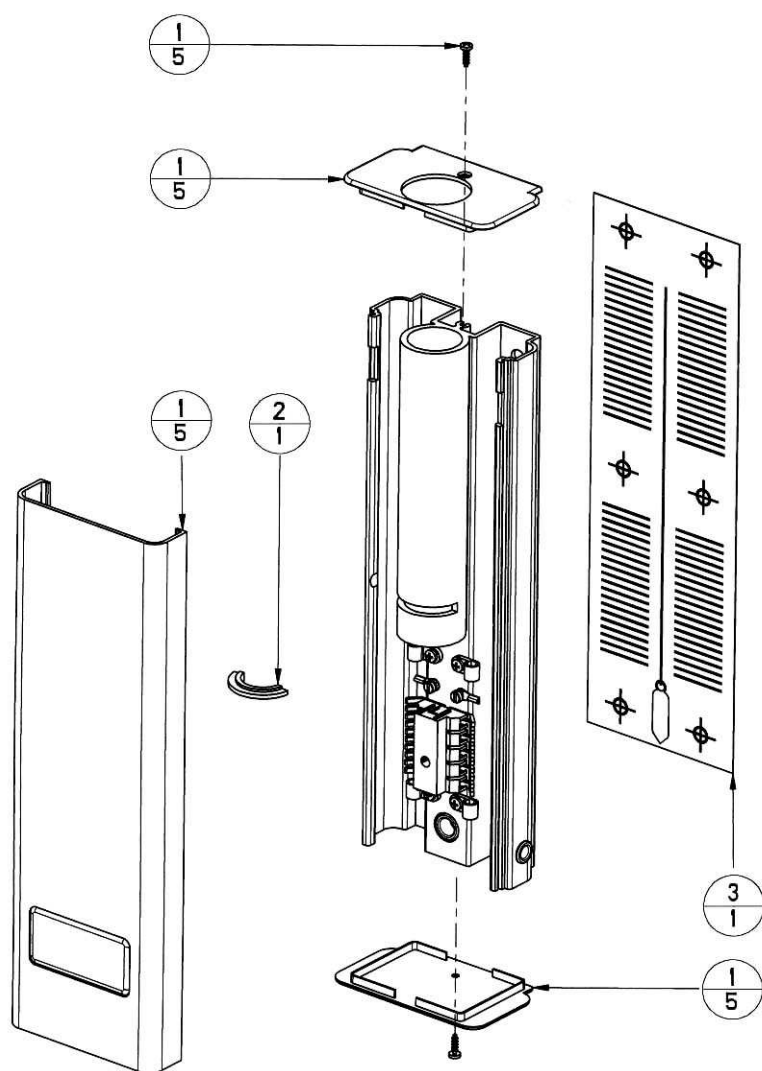




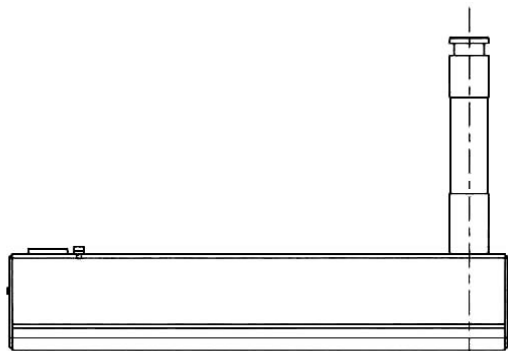
REF	SPARE PARTS PANTOGRAPH TYPE ARM X-MIND®	CODE	Q.TY PCS
1	AC XG B (1) CAVO + CONNETTORE 3 POLI	39700384	1
2	DC XG B (2) CAVO + CONNETTORE 5 POLI	39700381	1
3	AC/DC XG B (3) GUSCI LATO TESTA	29700990	9
4	BRACCIO PANTOGRAFO TIRANTE ANTERIORE	29700460	4
5	BRACCIO PANTOGRAFO PORTATIRANTE	29700458	6
6	AC/DC XG B (6) TAPPI (set)	29700991	7
7	AC/DC XG B (7) COPERTURA EST	27500757	1
8	AC/DC XG B (8) COPERTURA INT	27500758	1
9	AC/DC XG B (9) GUSCI CENTRALI	29700993	8
10	BRACCIO PANTOGRAFO CHIAVE CARICAMENTO	22000543	1
11	AC/DC XG B (11) COPERTURA INT	27500758	1
12	AC/DC B (12) COPERTURA EST	27500757	1
13	AC/DC XG B (13) TIRANTE POST	29700992	7
14	BRACCIO PANTOGRAFO LUNETTA	22000177	1
15	AC/DC B (15) GUSCI LATO MENSOLA	29700994	8



REF	SPARE PARTS WALL PLATE 350	CODE	Q.TY PCS
1	PIASTRA (1) COPERTURA	29700985	5
1	AC/DC XG PIASTRA (1) COPERTURA SAT	29700986	5
2	PIASTRA LUNETTA	22000176	1
3	PIASTRA (3) DIMA	24200984	1
	PIASTRA MURO 350 DEG	29700383	COMPLETO
	AC/DC XG PIASTRA MURO 350 SAT	29700987	COMPLETO



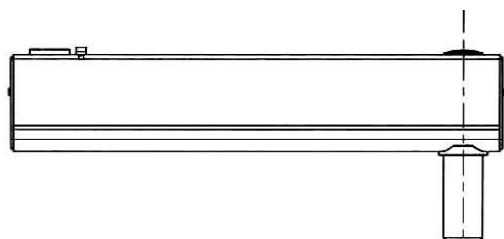
REF	SPARE PARTS WALL PLATE 350 TOP	CODE	Q.TY PCS
1	PIASTRA (1) COPERTURA	29700985	5
1	AC/DC XG PIASTRA (1) COPERTURA SAT	29700986	5
2	PIASTRA LUNETTA	22000176	1
3	PIASTRA (3) DIMA TOP	24201002	1
	PIASTRA MURO 350 TOP DEG	29700988	COMPLETO
	AC/DC XG PIASTRA MURO 350 TOP SAT	29700989	COMPLETO



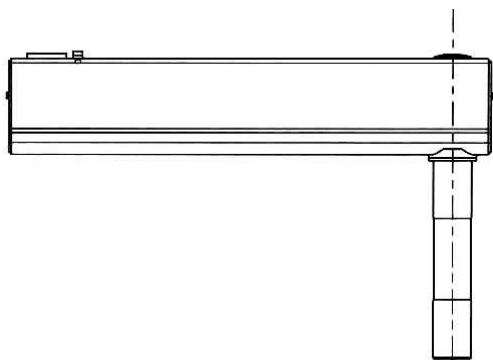
REF	SPARE PARTS BRACKET	CODE	Q.TY PCS
	MENSOLA 400	29700380	COMPLETO
	MENSOLA 800	29700378	COMPLETO
	MENSOLA 1100	29700379	COMPLETO



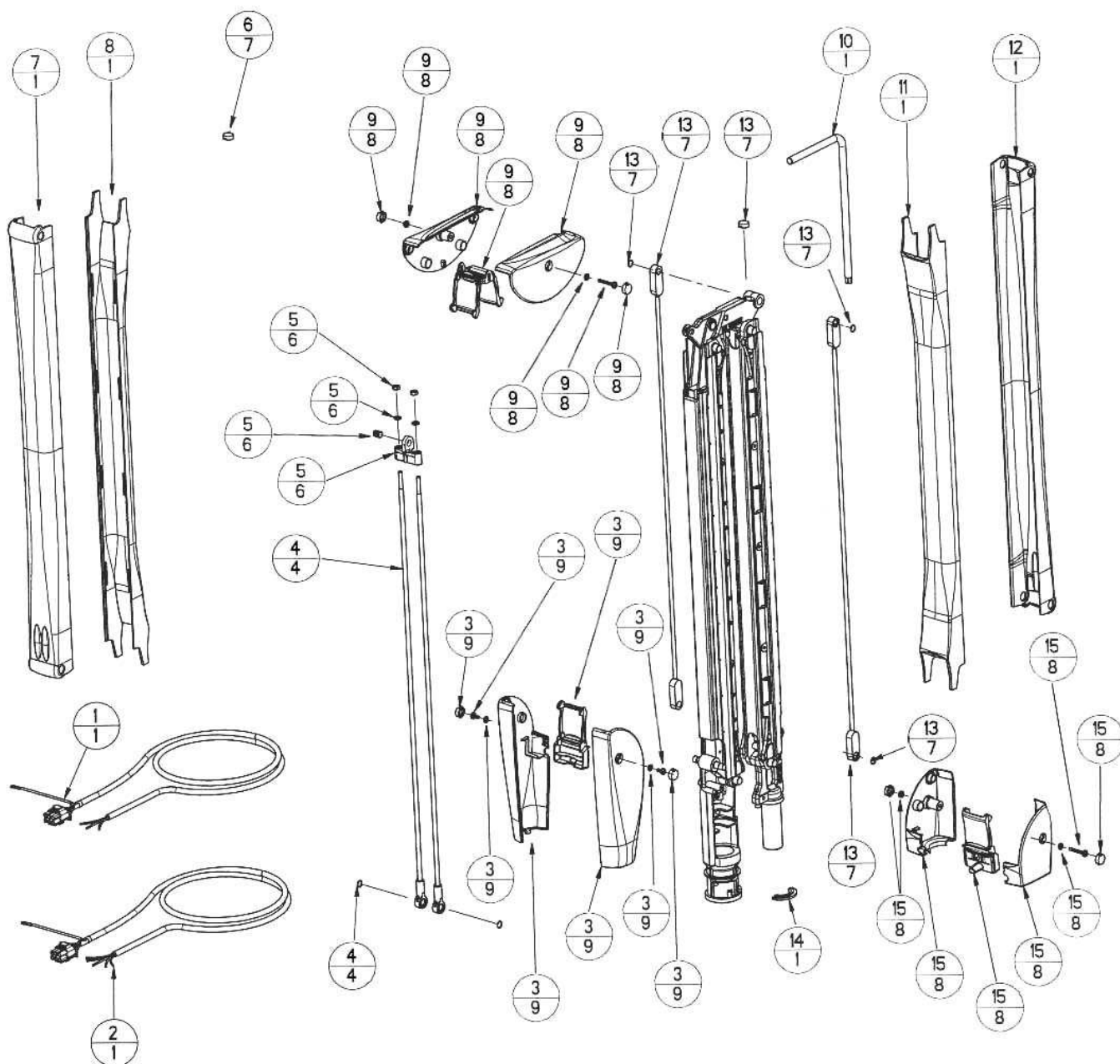
REF	SPARE PARTS CEILING BRACKET	CODE	Q.TY PCS
	MENSOLA PLAFONE	29700382	COMPLETO



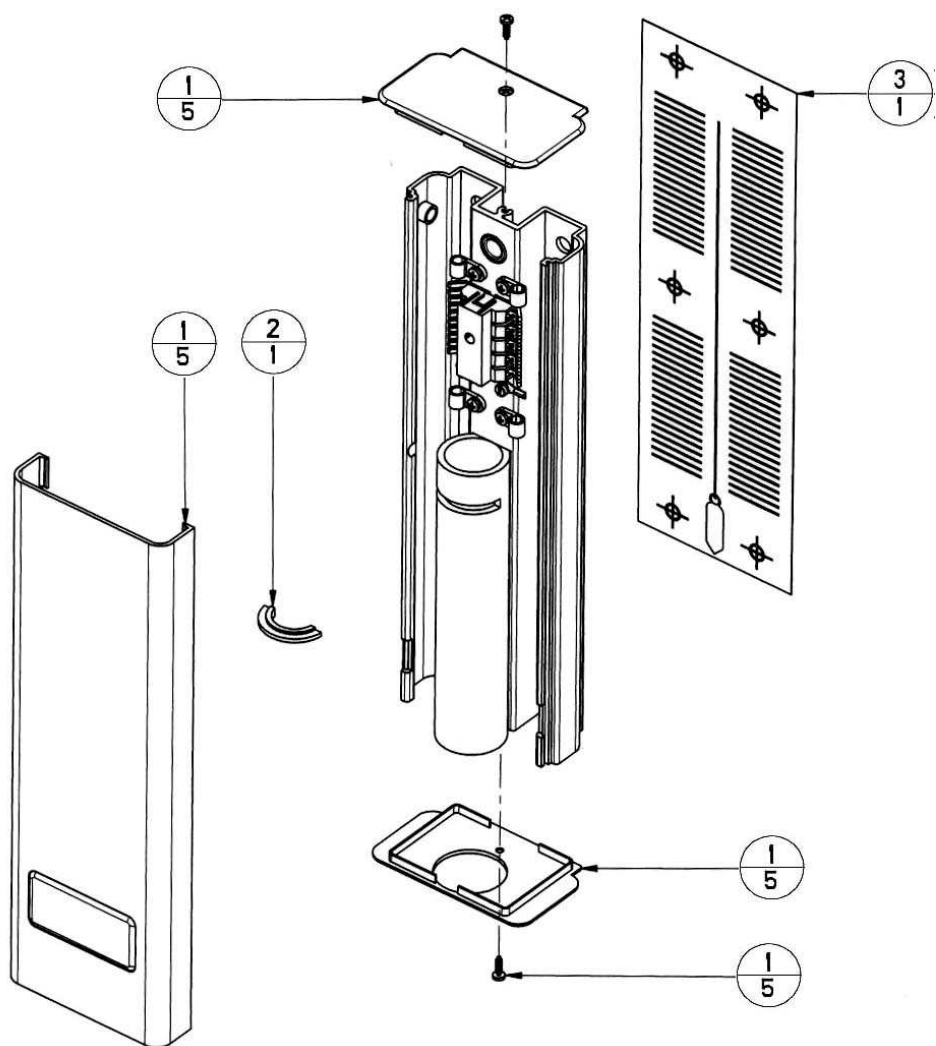
REF	SPARE PARTS UNIT BRACKET	CODE	Q.TY PCS
	MENSOLA RIUNITO	29700381	COMPLETO



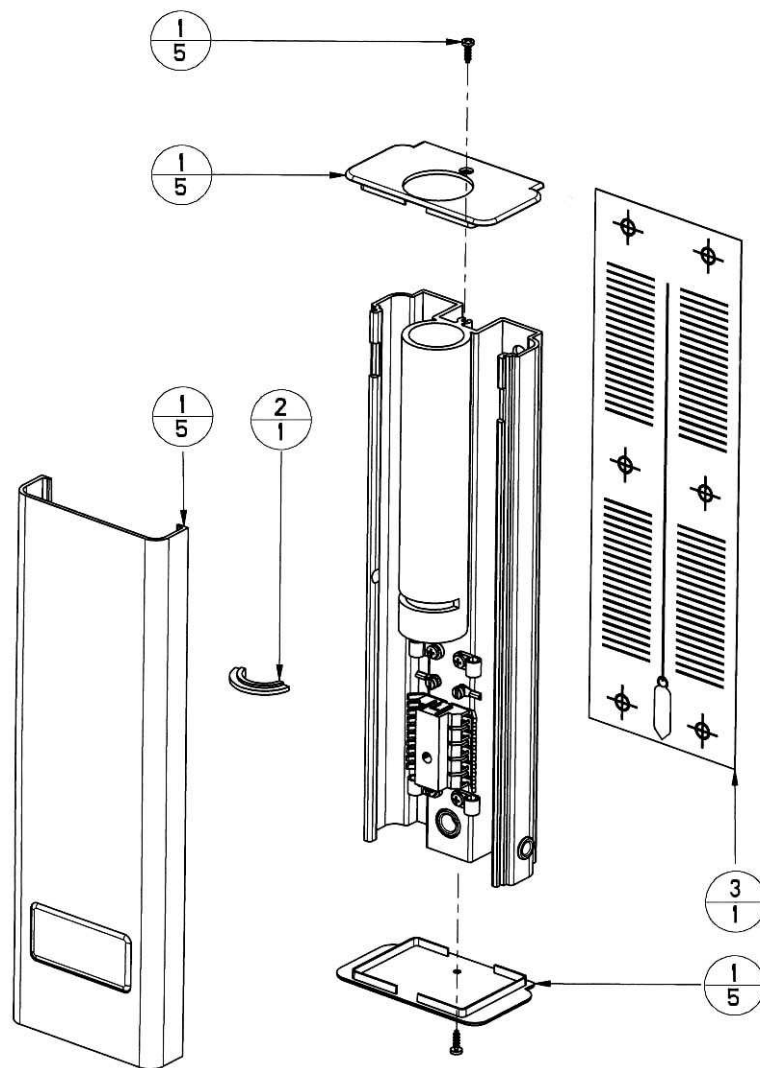
REF	SPARE PARTS TOP MOUNT BRACKET	CODE	Q.TY PCS
	MENSOLA 400 TOP MOUNT	29700620	COMPLETO
	MENSOLA 800 TOP MOUNT	29700621	COMPLETO
	MENSOLA 1100 TOP MOUNT	29700622	COMPLETO



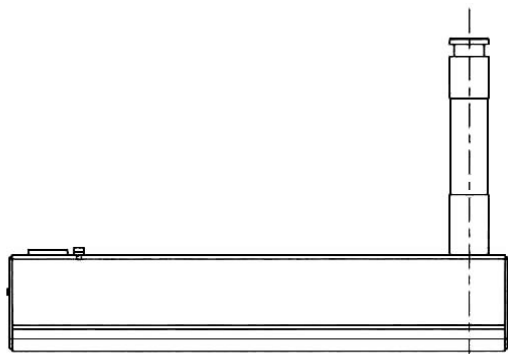
REF	WISSELSTUKKEN RICHTARM X-MIND®	CODE	AANTAL
1	AC XG B (1) CAVO + CONNETTORE 3 POLI	39700384	1
2	DC XG B (2) CAVO + CONNETTORE 5 POLI	39700381	1
3	AC/DC XG B (3) GUSCI LATO TESTA	29700990	9
4	BRACCIO PANTOGRAFO TIRANTE ANTERIORE	29700460	4
5	BRACCIO PANTOGRAFO PORTATIRANTE	29700458	6
6	AC/DC XG B (6) TAPPI (set)	29700991	7
7	AC/DC XG B (7) COPERTURA EST	27500757	1
8	AC/DC XG B (8) COPERTURA INT	27500758	1
9	AC/DC XG B (9) GUSCI CENTRALI	29700993	8
10	BRACCIO PANTOGRAFO CHIAVE CARICAMENTO	22000543	1
11	AC/DC XG B (11) COPERTURA INT	27500758	1
12	AC/DC B (12) COPERTURA EST	27500757	1
13	AC/DC XG B (13) TIRANTE POST	29700992	7
14	BRACCIO PANTOGRAFO LUNETTA	22000177	1
15	AC/DC B (15) GUSCI LATO MENSOLA	29700994	8



REF	WISSELSTUKKEN MUURPLAAT 350	CODE	AANTAL
1	PIASTRA (1) COPERTURA	29700985	5
1	AC/DC XG PIASTRA (1) COPERTURA SAT	29700986	5
2	PIASTRA LUNETTA	22000176	1
3	PIASTRA (3) DIMA	24200984	1
	PIASTRA MURO 350 DEG	29700383	COMPLETO
	AC/DC XG PIASTRA MURO 350 SAT	29700987	COMPLETO



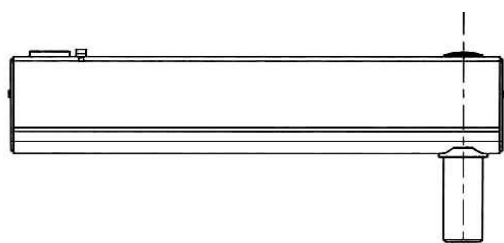
REF	WISSELSTUKKEN MUURPLAAT 350 TOP	CODE	AANTAL
1	PIASTRA (1) COPERTURA	29700985	5
1	AC/DC XG PIASTRA (1) COPERTURA SAT	29700986	5
2	PIASTRA LUNETTA	22000176	1
3	PIASTRA (3) DIMA TOP	24201002	1
	PIASTRA MURO 350 TOP DEG	29700988	COMPLETO
	AC/DC XG PIASTRA MURO 350 TOP SAT	29700989	COMPLETO



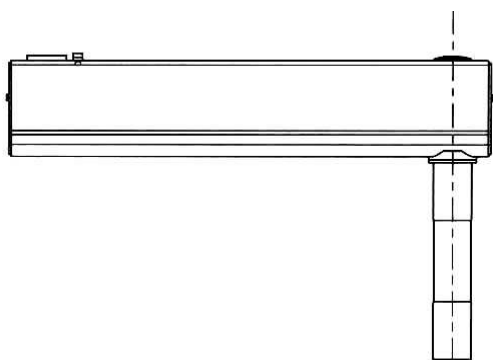
REF	WISSELSTUKKEN BEUGEL	CODE	AANTAL
	MENSOLA 400	29700380	COMPLETO
	MENSOLA 800	29700378	COMPLETO
	MENSOLA 1100	29700379	COMPLETO



REF	WISSELSTUKKEN PLAFONDBEUGEL	CODE	AANTAL
	MENSOLA PLAFONE	29700382	COMPLETO



REF	WISSELSTUKKEN EENHEIDBEUGEL	CODE	AANTAL
	MENSOLA RIUNITO	29700381	COMPLETO



REF	WISSELSTUKKEN BOVENBEUGEL	CODE	AANTAL
	MENSOLA 400 TOP MOUNT	29700620	COMPLETO
	MENSOLA 800 TOP MOUNT	29700621	COMPLETO
	MENSOLA 1100 TOP MOUNT	29700622	COMPLETO



# SATELEC

## France

SATELEC ACTEON GROUP  
17 av. Gustave Eiffel - B.P. 216 - F-33708 MERIGNAC cedex  
Tel. +33 (0) 556 34 06 07  
Fax. +33 (0) 556 34 92 92  
e-mail : satelec@acteongroup.com

## U.S.A.

ACTEON NORTH AMERICA  
130 Gaither Drive, Suite 100,  
MOUNT LAUREL NJ 08034 - U.S.A.  
Tel. +1 856 222 9988  
Fax. +1 856 222 4726  
e-mail : info@us.acteongroup.com

## GERMANY

ACTEON GERMANY  
Industriestrasse 9 - D-40822 METTMANN  
Tel. +49 21 04 95 65 10  
Fax. +49 21 04 95 65 11  
e-mail : info@de.acteongroup.com

## SPAIN

ACTEON IBERICA  
Avda Principal n° 11 H - Poligono Industrial Can Clapers  
E-08181 SENTMENAT (BARCELONA)  
Tel. +34 93 715 33 66  
Fax. +34 93 715 32 29  
e-mail : info@es.acteongroup.com

## U.K.

SATELEC (UK) LIMITED  
Unit 1B - Steel Close - Eaton Cocon, St Neots  
GB-CAMBS PE19 8TT  
Tel. +44 1480 477 307  
Fax. +44 1480 477 381  
e-mail : info@uk.acteongroup.com

## MIDDLE EAST

ACTEON MIDDLE EAST  
Numan Center - 1st Floor N° 111 - Gardens Street  
PO Box 468 - AMMAN 11953 - JORDAN  
Tel. +962 6 553 4401  
Fax. +962 6 553 7833  
e-mail : info@me.acteongroup.com

## CHINA

ACTEON CHINA  
Office 401 - 12 Xinyuanxili Zhong Street - Chaoyang District - BEIJING  
100027 - CHINA  
Tel. +86 10 646 570 11/2/3  
Fax. +86 10 646 580 15  
e-mail : info@cn.acteongroup.com

## PHILIPPINES

ACTEON PHILIPPINES  
3F King's Court II Bldg. - Corner Pasong Tamo & de la Rosa Street -  
Makati City - 1200 METRO MANILA - PHILIPPINES  
Tel. +632 811 2487  
Fax. +632 811 2488  
e-mail : info@ph.acteongroup.com

## THAILAND

ACTEON (THAILAND) LTD  
23/81 Sorachai Bldg 20th floor - Sukumvit 63 Road - Klongtan Nua  
Wattana - 10110 BANGKOK - THAILAND  
Tel. +66 2 714 3295  
Fax. +66 2 714 3296  
e-mail : info@th.acteongroup.com

## KOREA

ACTEON KOREA  
8F Hanil B/D - 132-4 1Ga Bongrae-dong - JOONG-GU - SEOUL - KOREA  
Tel. +82 2 753 41 91  
Fax. +82 2 753 41 93  
e-mail : info@kr.acteongroup.com

## INDIA

ACTEON INDIA  
E-91, G.I.D.C. Electronic Estate - Sector 26 - GANDHINAGAR 382044  
(Gujarat)  
Tel. ++91 79 2323 8000  
Fax. ++91 79 2646 2041  
e-mail : info@in.acteongroup.com

