

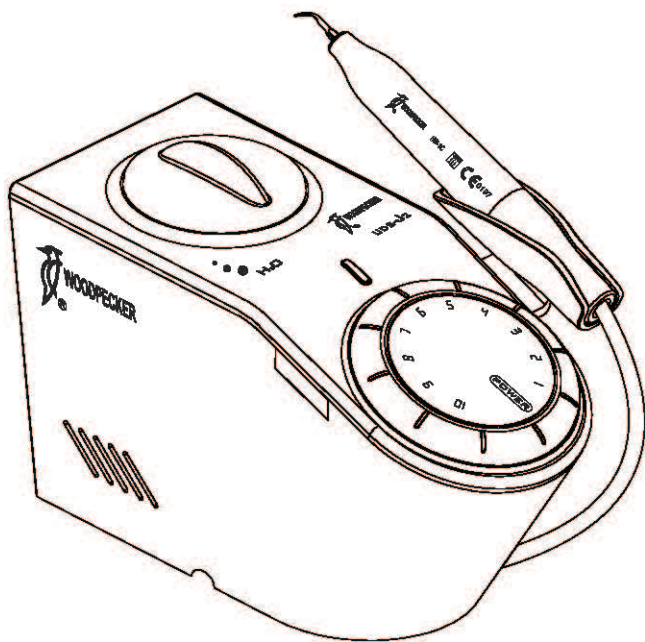

Industrial design patent No.: CN 201130027363.1  
Please read this manual before operating

# UDS-J2 ULTRASONIC SCALER

## INSTRUCTION MANUAL



**FDA CE** 0197

[www.glwoodpecker.com](http://www.glwoodpecker.com)

**GUILIN WOODPECKER MEDICAL INSTRUMENT CO., LTD.**

## Contents

|                                                 |    |
|-------------------------------------------------|----|
| 1 The installation and components of equipment  | 1  |
| 1.1 Instruction                                 | 1  |
| 1.2 Components                                  | 1  |
| 1.3 The main technical specifications           | 1  |
| 1.4 Instruction of the main components          | 2  |
| 2. Installation and adjustment                  | 3  |
| 3. Maintenance and sterilization                | 4  |
| 4. Precaution                                   | 6  |
| 5. After service                                | 8  |
| 6. Environmental protection                     | 9  |
| 7. Manufacturer's right                         | 9  |
| 8. For technical data, please contact           | 9  |
| 9. Symbol instruction                           | 9  |
| 10. Declaration of conformity                   | 10 |
| 10.1 Product conformity the following standards | 10 |
| 10.2 EMC-Declaration of conformity              | 10 |
| 11. Statement                                   | 14 |

## **1. The installation and components of equipment**

### **1.1 Instruction**

Guilin Woodpecker Medical Instrument Co., Ltd. is a professional manufacturer in researching, developing and producing ultrasonic scalers. The product is mainly used for teeth cleaning and also an indispensable equipment for tooth disease prevention and treatment.

The ultrasonic scaler UDS-J2 has scaling, perio functions with the following features:

1.1.1 The silicon-cover can be autoclaved to high temperature 135°C and high pressure 0.22Mpa.

1.1.2 Automatic frequency tracking ensures that the machine always works on the best frequency and more steadily.

1.1.3 Digitally controlled, easy operation and more efficient for scaling.

### **1.2 Components**

1.2.1 The components of machine are listed in the packing list.

#### **1.2.2 Product performance and structural composition**

Ultrasonic scaler UDS-J2 is composed of electrocircuit, water way and ultrasonic transducer.

#### **1.2.3 Scope of application**

Ultrasonic scaler UDS-J2 is used for the dental calculus elimination.

### **1.3 The main technical specifications**

#### **1.3.1 Technical specifications of ultrasonic scaler**

- a) Main unit input: 110V~ 50Hz/60Hz 150mA
- b) Output primary tip vibration excursion:  $\leq 100\mu\text{m}$
- c) Output half-excursion force:  $< 2\text{N}$
- d) Output tip vibration frequency:  $30\text{kHz} \pm 3\text{kHz}$
- e) Output power: 3W to 20W
- f) Main unit fuse: T0.5AL 250V
- g) Water pressure: 0.01MPa to 0.5MPa

- h) Weight of main unit: 1.7kg
- i) Operating mode: Continuous operation
- j) Type of protection against electric shock: class II equipment
- k) Degree of protection against electric shock: Type BF applied part
- l) Applied part of the equipment: handpiece and tip
- m) Degree of protection against harmful ingress of water: Ordinary equipment, the foot switch is drip-proof equipment (IPX1)
- n) Degree of safety of application in the presence of a Flammable Anesthetic Mixture with air, Oxygen or Nitrous Oxide: Equipment not suitable for being used in the presence of a flammable anesthetic mixture with air, oxygen or nitrous oxide.

## 1.4 Instruction of the main components

### Instruction and component sketch map

#### 1.4.1 Front of the main unit sketch map

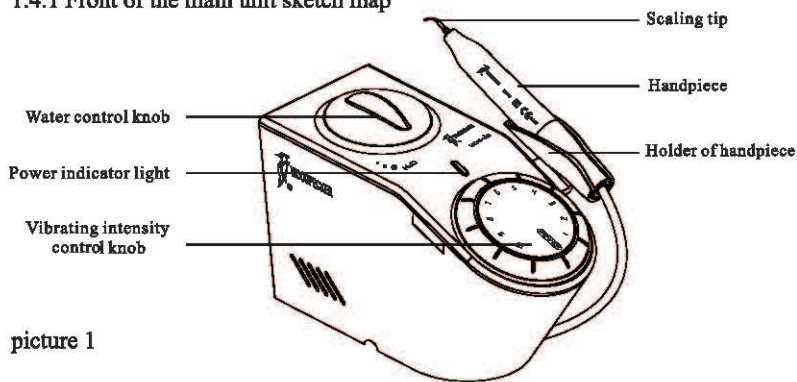

picture 1

#### 1.4.2 Back of the main unit sketch map

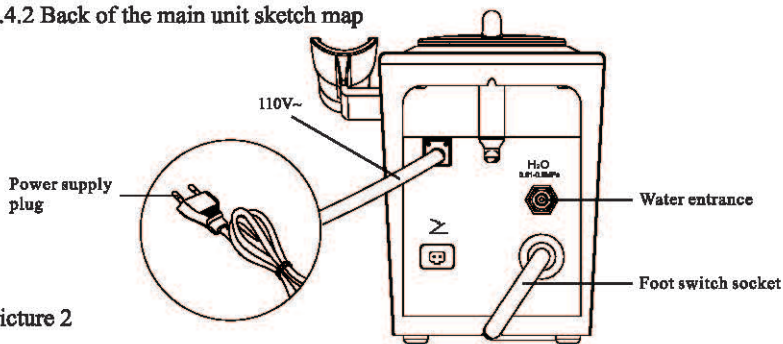

Picture 2

### 1.4.3 Instruction of using wrench



picture 3

## 2. Installation and adjustment

### 2.1 Operation

2.1.1 Open the packing box, make sure that all the parts and accessories are complete according to the packing list, take the main unit out of the box, and put it on the stable plane facing to the operator.

2.1.2 Turn the water control knob to the max according to the picture direction [note 1].

2.1.3 Insert the plug of the foot switch to its socket. (see picture 2)

2.1.4 Connect one end of water pipe to the water pipe to the water entrance, and the other end to the clean water source. (see picture 2)

2.1.5 Choose the scaling tip according to the requirement, and fix the scaling tip with the wrench. (see picture 3)

2.1.6 Connect the power cord to the main unit, and get through to the power. (see picture 2)

2.1.7 Turn the power switch to clockwise direction till hearing the "pa" sound, now the power is turned on and power indicator lights on. Then the power indicator shines.

2.1.8 Under normal working condition, the frequency of the tips is very high, light touch and a certain to-and-fro motion will eliminate the tartar without obvious heating, overexertion and overstay are forbidden.

2.1.9 Vibrating intensity: Adjust the vibrating intensity according to your need, usually adjust to the middle grade, and adjust the vibrating during the clinical treatment according to the patient's sensitivity and the rigidity of the tartar.

2.1.10 Water volume adjustment: Step on the foot switch, and the tip begins to vibrate, then turn the water control switch to from fine spray to cool down the

handpiece and clean the teeth.

2.1.11 The handpiece can be handled in the same gesture as a pen in hand.

2.1.12 Be sure not to make the end of the tip touch the teeth vertically, and not use too much pressure when the tip touch the surface of the teeth, in order not to hurt the teeth and the tip.

2.1.13 After finishing operation, keep the machine working for 30 seconds with the water supply to clean the handpiece and the tip.

2.1.14 Unscrew the scaling tip and sterilize it.

**Note: Don't screw the scaling tips when stepping on the foot switch, and the machine is working.**

### 3. Maintenance and sterilization

3.1 All the scaling tips can be autoclaved.

3.2 Handpiece can be sterilized by any neutral sterilized liquid for cleaning and sterilizing. Do not sterilize under the high temperature and pressure.

3.3 The scaling tip and wrench can be cleaned by ultrasonic cleaner.

3.4 Troubles shotting

3.4.1 Trouble shotting

| Fault                                                                                            | Possible                                                                        | Solutions                                           |
|--------------------------------------------------------------------------------------------------|---------------------------------------------------------------------------------|-----------------------------------------------------|
| The scaling tip doesn't vibrate and no water flowing out when stepping on the foot switch.       | The plug is in loose or wrong contact.                                          | Connect the power plug well.                        |
|                                                                                                  | The foot switch is in loose contact.                                            | Connect the switch well.                            |
|                                                                                                  | The fuse of transformer is broken.                                              | Change a new T0.5AL 250V fuse.                      |
| The scaling tip doesn't vibrate, but there is waterflowing out when stepping on the foot switch. | The scaling tip is in loose contact.                                            | Screw it tightly (see picture 3)                    |
|                                                                                                  | The connector plug of the handpiece with the circuit board is in loose contact. | Contact with the local distributor or manufacturer. |
|                                                                                                  | Malfunction of the handpiece.                                                   | Contact with the local distributor or manufacturer. |

| Fault                                                                                     | Possible                                                                   | Solutions                                                 |
|-------------------------------------------------------------------------------------------|----------------------------------------------------------------------------|-----------------------------------------------------------|
| The scaling tip vibrates but there is no spray come out when stepping on the foot switch. | The water control switch is turn off.                                      | Turn on the switch [note 1].                              |
|                                                                                           | There is impurity in the solenoid valve.                                   | Contact with the local distributor or manufacturer.       |
|                                                                                           | The water pipe is jammed.                                                  | Clean water pipe by multi-function syringe [note 2].      |
| There is water flow out when turn off the power.                                          | There is impurity in the solenoid valve.                                   | Contact with the local distributor or manufacturer.       |
| The handpiece generates heat.                                                             | The amount of spouting water is too little.                                | Turn the water control switch to a higher grade [note 1]. |
|                                                                                           | The potentiometer is broken.                                               | Change a new one.                                         |
| The amount of spouting water is too little.                                               | The water control knob is a low grade.                                     | Turn the knob to a high grade [note 1].                   |
|                                                                                           | The water pressure is not enough.                                          | Enhance the water pressure.                               |
|                                                                                           | The water pipe is jammed.                                                  | Clean water pipe with multi-function syringe [note2].     |
| The vibration of the tip becomes weak.                                                    | The tip hasn't been screwed tightly or becomes loose because of vibration. | Screw the scaling tip tightly (picture 3).                |
|                                                                                           | The tip is damaged.[note 3]                                                | Change a new one.                                         |
|                                                                                           | The tip is damaged [ note 3 ].                                             | Change a new one.                                         |
| The vibrating intensity control knob is seized up.                                        | The potentiometer is damaged.                                              | Contact with the local distributor or our company.        |

If the troubles still can't be solved, please contact with the local distributors or manufacturer.

### 3.4.2 Notice

[Note 1] The water control knob can adjust the water volume according to the symbol.

[Note 2] To clean the water pipe with the multi-function syringe of the dental unit ( see picture 4):

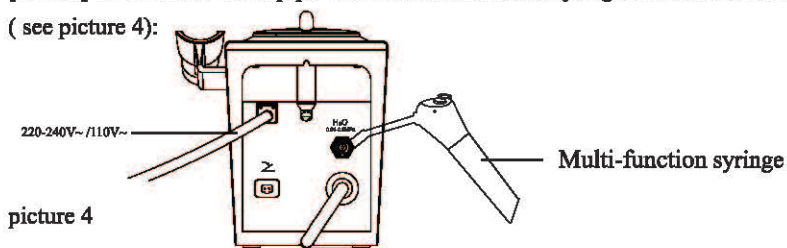

- Snip the water pipe at a distance of 10cm to 20cm from the water entrance.
- Turn on the power switch, get through to the power.
- Connect the multi-function syringe of the dental unit to the water pipe.
- Screw off the scaling tip or pull out the handpiece.
- Step on the foot switch.
- Turn on the switch of the multi-function syringe, press the air or water into the water pipe to clean and eliminate the impurity.

[Note 3 ] If the scaling tip has been screwed on tightly and there is fine spray too, the following phenomena show that the scaling tip is damaged:

- The vibrating intensity and the pulverization degree become weak obviously.
- During operating, there is some buzz when the scaling tip is working.

## 4. Precaution

### 4.1 usage notice

- Keep the scaler clean before and after operation.
- The scaling tip, wrench and handpiece must be sterilized before each treatment.
- Don't screw the scaling tip when stepping on the foot switch.



4.1.4 The scaling tip must be fastened. There must be fine spray coming out from the tip when operating.

4.1.5 Change a new one when the tip is damaged or worn excessively.

4.1.6 While scaler working, the heat of scaling tip will become higher if there is no water flowing out. Please keep the water flow smoothly.

4.1.7 Don't twist or rub the tip.

4.1.8 Don't use impure water source, and be sure not to use normal brine instead of pure water source.

4.1.9 If use the water source without hydraulic pressure, the water surface should be one meter higher than the head of the patient.

4.1.10 Don't knock or rub the handpiece.

4.1.11 Please put the power plug into the socket easy to pull out, to make sure it can be pull out in emergency.

4.1.12 When using the equipment, please keep the water get through smoothly, otherwise patient's tooth surface would be injured by overheat in the handpiece.

4.1.13 After operating, turn off electrical source, and then pull out the plug.

4.1.14 As a professional manufacturer of medical instruments, we are only responsible for the safety on the following conditions:

I . The maintenance, repair and modification are made by the manufacturer or the authorized dealer.

II . The changed components are original of "WOODPECKER" and operated correctly according to instruction manual.

4.1.15 The screw thread of the scaling tips produced by other manufacturers maybe coarse, rusty and collapsed, which will damage the screw thread of the handpiece irretrievably. Please use "WOODPECKER" brand scaling tip.

4.1.16 Please select a suitable power when using different type of tips (refer to "TABLE OF OPERATING POWER OF THE TIPS").

## 4.2 Contraindication

4.2.1 The patient who has hemophilia is not allowed to use this equipment.

4.2.2 The patient or doctor who with heart pacemaker is forbidden to use this equipment.

4.2.3 The heart disease patient, pregnant woman and children should be cautious to use the equipment.

#### 4.3 Storage and maintenance

4.3.1 The equipment should be handled carefully and lightly. Be sure that it is far from the vibration, and is installed or kept in a cool, dry and ventilated place.

4.3.2 Don't store the machine together with the articles that are combustible poisonous, caustic, or explosive.

4.3.3 This equipment should be stored in a room where the relative humidity is  $\leq 80\%$ , atmospheric pressure is 50kPa to 106kPa, and the temperature is  $-10^{\circ}\text{C}$  to  $+50^{\circ}\text{C}$ .

4.3.4 Please turn off the power switch and pull out the power plug when the equipment is not used. If the machine is not used for a long time, please make it get through to the power and water once per month for five minutes.

#### 4.4 Transportation

4.4.1 Excessive impact and shake should be prevented in transportation. Lay it carefully and lightly and don't invert it.

4.4.2 Don't put it together with dangerous goods during transportation.

4.4.3 Avoid solarization and getting wet in rain or snow during transportation.

#### 4.5 Working condition

Environment temperature:  $+5^{\circ}\text{C}$  to  $+40^{\circ}\text{C}$

Relative humidity:  $\leq 80\%$

Atmosphere pressure: 70kPa to 106kPa

### 5. After service

We offer one year free repair to the equipment according to the warranty card.

The repair of the equipment should be carried out by professional technician. We are not responsible for any irretrievable damage caused by the not professional person.

## 6. Environmental protection

There are no harmful factors in our product. You can deal with it based on the local law.

## 7. Manufacturer's right

We reserve the rights to change the design of the equipment, the technique, fittings, the instruction manual and the content of the original packing list at any time without notice. If there are some differences between blueprint and real equipment, take the real equipment as the norm.

## 8. For technical data, please contact

**EC REP** Wellkang Ltd ([www.CE-Marking.eu](http://www.CE-Marking.eu))  
29 Harley St., LONDON, W1G 9QR, UK

## 9. Symbol instruction



Trademark



Manufacturer



Consult the accompanying documents

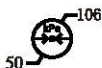

Atmospheric pressure for storage



Date of manufacture



Class II equipment

IPX1

Drip-proof



Type BF applied part



Foot switch interface



Used indoor only



CE marked product



Alternating current



FDA marked product



Adjustment for the water flow

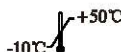

Temperature limitation

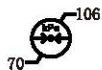

Atmospheric pressure for working



Recovery

110V~

Power input



Keep dry



Humidity limitation



Handle with care

H<sub>2</sub>O  
0.01MPa to 0.5MPa

Water entrance pressure



Appliance compliance WEEE directive



Authorised Representative in the EUROPEAN COMMUNITY

## 10. Declaration of conformity

### 10.1 Product conformity the following standards

EN 60601-1:2006

EN 60601-1-2:2007

EN 60601-1-6:2010

EN 62366:2008

EN 61205:1994

EN ISO 22374:2005

EN 62304:2006

EN 980:2008

EN ISO 9687:1995

EN 1041:2008

ISO 15223-1:2012

EN ISO 14971:2012

EN ISO 7405:2008 +A1:2003

EN ISO 17664:2004

EN ISO 17665-1:2006

EN ISO 10993-1:2009

EN ISO 10993-5:2009

EN ISO 10993-10:2010

### 10.2 EMC - Declaration of conformity

| Guidance and manufacturer's declaration - electromagnetic emissions                                                                                                                         |            |                                                                                                                                                                                                   |
|---------------------------------------------------------------------------------------------------------------------------------------------------------------------------------------------|------------|---------------------------------------------------------------------------------------------------------------------------------------------------------------------------------------------------|
| The model UDS-J2 is intended for use in the electromagnetic environment specified below. The customer or the user of the model UDS-J2 should assure that it is used in such an environment. |            |                                                                                                                                                                                                   |
| Emissions test                                                                                                                                                                              | Compliance | Electromagnetic environment - guidance                                                                                                                                                            |
| RF emissions<br>CISPR 11                                                                                                                                                                    | Group 1    | The model UDS-J2 uses RF energy only for its internal function. Therefore, its RF emissions are very low and are not likely to cause any interference in nearby electronic equipment.             |
| RF emissions<br>CISPR11                                                                                                                                                                     | Class B    | The model UDS-J2 is suitable for use in domestic establishment and in establishment directly connected to a low voltage power supply network which supplies buildings used for domestic purposes. |
| Harmonic emissions<br>IEC 61000-3-2                                                                                                                                                         | Class A    |                                                                                                                                                                                                   |
| Voltage fluctuations<br>/ flicker emissions<br>IEC 61000-3-3                                                                                                                                | Complies   |                                                                                                                                                                                                   |

| Guidance & Declaration — electromagnetic immunity                                                                                                                                           |                                                                                                                                                                                                                  |                                                                                                                                                                                                                  |                                                                                                                                                                                                                                                                                          |
|---------------------------------------------------------------------------------------------------------------------------------------------------------------------------------------------|------------------------------------------------------------------------------------------------------------------------------------------------------------------------------------------------------------------|------------------------------------------------------------------------------------------------------------------------------------------------------------------------------------------------------------------|------------------------------------------------------------------------------------------------------------------------------------------------------------------------------------------------------------------------------------------------------------------------------------------|
| The model UDS-J2 is intended for use in the electromagnetic environment specified below. The customer or the user of the model UDS-J2 should assure that it is used in such an environment. |                                                                                                                                                                                                                  |                                                                                                                                                                                                                  |                                                                                                                                                                                                                                                                                          |
| Immunity test                                                                                                                                                                               | IEC 60601 test level                                                                                                                                                                                             | Compliance level                                                                                                                                                                                                 | Electromagnetic environment - guidance                                                                                                                                                                                                                                                   |
| Electrostatic discharge (ESD)<br>IEC 61000-4-2                                                                                                                                              | ±6 kV contact<br>±8 kV air                                                                                                                                                                                       | ±6 kV contact<br>±8 kV air                                                                                                                                                                                       | Floors should be wood, concrete or ceramic tile. If floors are covered with synthetic material, the relative humidity should be at least 30 %.                                                                                                                                           |
| Electrical fast transient/burst<br>IEC 61000-4-4                                                                                                                                            | ±2kV for power supply lines<br>±1 kV for input/output lines                                                                                                                                                      | ±2kV for power supply lines<br>±1kV for interconnecting cable                                                                                                                                                    | Mains power quality should be that of a typical commercial or hospital environment.                                                                                                                                                                                                      |
| Surge<br>IEC 61000-4-5                                                                                                                                                                      | ±1 kV line to line<br>±2 kV line to earth                                                                                                                                                                        | ±1 kV line to line                                                                                                                                                                                               | Mains power quality should be that of a typical commercial or hospital environment.                                                                                                                                                                                                      |
| Voltage dips, short interruptions and voltage variations on power supply input lines<br>IEC 61000-4-11.                                                                                     | <5 % $U_T$<br>(>95% dip in $U_T$ )<br>for 0.5 cycle<br>40 % $U_T$<br>(60% dip in $U_T$ )<br>for 5 cycles<br>70% $U_T$<br>(30% dip in $U_T$ )<br>for 25 cycles<br><5% $U_T$<br>(>95 % dip in $U_T$ )<br>for 5 sec | <5 % $U_T$<br>(>95% dip in $U_T$ )<br>for 0.5 cycle<br>40 % $U_T$<br>(60% dip in $U_T$ )<br>for 5 cycles<br>70% $U_T$<br>(30% dip in $U_T$ )<br>for 25 cycles<br><5% $U_T$<br>(>95 % dip in $U_T$ )<br>for 5 sec | Mains power quality should be that of a typical commercial or hospital environment. If the user of the model UDS-J2 requires continued operation during power mains interruptions, it is recommended that the model UDS-J2 be powered from an uninterruptible power supply or a battery. |
| Power frequency (50/60 Hz) magnetic field<br>IEC 61000-4-8                                                                                                                                  | 3 A/m                                                                                                                                                                                                            | 3 A/m                                                                                                                                                                                                            | Power frequency magnetic fields should be at levels characteristic of a typical location in a typical commercial or hospital environment.                                                                                                                                                |
| NOTE $U_T$ is the a.c. mains voltage prior to application of the test level.                                                                                                                |                                                                                                                                                                                                                  |                                                                                                                                                                                                                  |                                                                                                                                                                                                                                                                                          |

**Guidance & Declaration - Electromagnetic Immunity**

The model UDS-J2 is intended for use in the electromagnetic environment specified below. The customer or the user of the model UDS-J2 should assure that it is used in such an environment.

| Immunity test                                                 | IEC 60601 test level                                      | Compliance level | Electromagnetic environment - guidance                                                                                                                                                                                                                                                                                                                                                                                                                                                                                                                                                                                                                                                                                                                                                                                                                                |
|---------------------------------------------------------------|-----------------------------------------------------------|------------------|-----------------------------------------------------------------------------------------------------------------------------------------------------------------------------------------------------------------------------------------------------------------------------------------------------------------------------------------------------------------------------------------------------------------------------------------------------------------------------------------------------------------------------------------------------------------------------------------------------------------------------------------------------------------------------------------------------------------------------------------------------------------------------------------------------------------------------------------------------------------------|
| Conducted RF<br>IEC 61000-4-6<br>Radiated RF<br>IEC 61000-4-3 | 3 Vrms<br>150 kHz to 80 MHz<br>3 V/m<br>80 MHz to 2.5 GHz | 3V<br><br>3 V/m  | Portable and mobile RF communications equipment should be used no closer to any part of the model UDS-J2, including cables, than the recommended separation distance calculated from the equation applicable to the frequency of the transmitter.<br><br><b>Recommended separation distance</b><br>3V<br>$d=1.2 \times P^{1/2}$ 80 MHz to 800 MHz<br>$d=2.3 \times P$ 800 MHz to 2.5 GHz<br>where $P$ is the maximum output power rating of the transmitter in watts (W) according to the transmitter manufacturer and $d$ is the recommended separation distance in meters (m).<br>Field strengths from fixed RF transmitters, as determined by an electromagnetic site survey, <sup>a</sup> should be less than the compliance level in each frequency range. <sup>b</sup><br>Interference may occur in the vicinity of equipment marked with the following symbol: |

NOTE 1 At 80 MHz and 800 MHz, the higher frequency range applies.

NOTE 2 These guidelines may not apply in all situations. Electromagnetic propagation is affected by absorption and reflection from structures, objects and people.

<sup>a</sup> Field strengths from fixed transmitters, such as base stations for radio (cellular/cordless) telephones and land mobile radios, amateur radio, AM and FM radio broadcast and TV broadcast cannot be predicted theoretically with accuracy. To assess the electromagnetic environment due to fixed RF transmitters, an electromagnetic site survey should be considered. If the measured field strength in the location in which the model UDS-J2 is used exceeds the applicable RF compliance level above, the model UDS-J2 should be observed to verify normal operation. If abnormal performance is observed, additional measures may be necessary, such as reorienting or relocating the model UDS-J2.

<sup>b</sup> Over the frequency range 150 kHz to 80 MHz, field strengths should be less than 3V/m.

**Recommended separation distances between portable and mobile RF communications equipment and the model UDS-J2**

The model UDS-J2 is intended for use in electromagnetic environment in which radiated RF disturbances is controlled. The customer or the user of the model UDS-J2 can help prevent electromagnetic interference by maintaining a minimum distance between portable and mobile RF communications equipment (transmitters) and the model UDS-J2 as recommended below, according to the maximum output power of the communications equipment.

| Rated maximum output power of transmitter W | Separation distance according to frequency of transmitter m |                                           |                                            |
|---------------------------------------------|-------------------------------------------------------------|-------------------------------------------|--------------------------------------------|
|                                             | 150kHz to 80MHz<br>$d=1.2 \times P^{1/2}$                   | 80MHz to 800MHz<br>$d=1.2 \times P^{1/2}$ | 800MHz to 2,5GHz<br>$d=2.3 \times P^{1/2}$ |
| 0,01                                        | 0.12                                                        | 0.12                                      | 0.23                                       |
| 0,1                                         | 0.38                                                        | 0.38                                      | 0.73                                       |
| 1                                           | 1.2                                                         | 1.2                                       | 2.3                                        |
| 10                                          | 3.8                                                         | 3.8                                       | 7.3                                        |
| 100                                         | 12                                                          | 12                                        | 23                                         |

For transmitters rated at a maximum output power not listed above, the recommended separation distance  $d$  in meters (m) can be estimated using the equation applicable to the frequency of the transmitter, where  $P$  is the maximum output power rating of the transmitter in watts (W) accordable to the transmitter manufacturer.

NOTE 1 At 80 MHz and 800 MHz, the separation distance for the higher frequency range applies.

NOTE 2 These guidelines may not apply in all situations. Electromagnetic propagation is affected by absorption and reflection from structures, objects and people.

The device has been tested and homologated in accordance with EN 60601-1-2 for EMC. This does not guarantee in any way that this device will not be effected by electromagnetic interference. Avoid using the device in high electromagnetic environment.

## 11. Statement

All rights of modifying the product are reserved to the manufacturer without further notice. The pictures are only for reference. The final interpretation rights belong to GUILIN WOODPECKER MEDICAL INSTRUMENT CO., LTD. The industrial design, inner structure, etc, have claimed for several patents by WOODPECKER, any copy or fake product must take legal responsibilities.

**TABLE OF OPERATING POWER OF THE TIPS**

| Tip Model                 | Scaler Model<br>Power | UDS-E (LED) | UDS-J2 (LED) | UDS-J<br>UDS-B<br>UDS-K (LED) | UDS-N3 (LED) | UDS-N1<br>UDS-N2 (LED)<br>UDS-N4 | Compatible<br>Scaler Brand                                   |
|---------------------------|-----------------------|-------------|--------------|-------------------------------|--------------|----------------------------------|--------------------------------------------------------------|
|                           |                       | UDS-L (LED) | UDS-A (LED)  | UDS-P (LED)                   |              |                                  |                                                              |
| <b>Scaling</b>            |                       |             |              |                               |              |                                  |                                                              |
| G1                        | 1-10 (G)              | 1-10        | 1-10         | 1-9                           | LOW-HIGH     | LOW-HIGH                         | Compatible with<br>WOODPECKER<br>& EMS<br>Ultrasonic Scalers |
| G2                        | 1-10 (G)              | 1-10        | 1-10         | 1-9                           | LOW-HIGH     | LOW-HIGH                         |                                                              |
| G3                        | 1-10 (G)              | 1-10        | 1-10         | 1-9                           | LOW-HIGH     | LOW-HIGH                         |                                                              |
| G4                        | 1-10 (G)              | 1-10        | 1-10         | 1-9                           | LOW-HIGH     | LOW-HIGH                         |                                                              |
| G5                        | 1-10 (G)              | 1-10        | 1-10         | 1-9                           | LOW-HIGH     | LOW-HIGH                         |                                                              |
| G6                        | 1-10 (G)              | 1-10        | 1-10         | 1-9                           | LOW-HIGH     | LOW-HIGH                         |                                                              |
| G7                        | 1-10 (G)              | 1-10        | 1-10         | 1-9                           | LOW-HIGH     | LOW-HIGH                         |                                                              |
| G8                        | 1-10 (G)              | 1-10        | 1-10         | 1-9                           | LOW-HIGH     | LOW-HIGH                         |                                                              |
| G9                        | 1-10 (G)              | 1-10        | 1-10         | 1-9                           | LOW-HIGH     | LOW-HIGH                         |                                                              |
| G10                       | 1-10 (G)              | 1-10        | 1-10         | 1-9                           | LOW-HIGH     | LOW-HIGH                         |                                                              |
| G11                       | 1-10 (G)              | 1-10        | 1-10         | 1-9                           | LOW-HIGH     | LOW-HIGH                         |                                                              |
| <b>Periodontics</b>       |                       |             |              |                               |              |                                  |                                                              |
| P1                        | 1-10 (P)              | 1-7         | 1-7          | 1-6                           | LOW-MID      | LOW-MID                          | Compatible with<br>WOODPECKER<br>& EMS<br>Ultrasonic Scalers |
| P2L                       | 1-3 (P)               | 1-2         | 1-2          | 1-2                           | LOW          | LOW                              |                                                              |
| P2LD                      | 1-2 (P)               | 1           | 1            | 1                             | LOW          | LOW                              |                                                              |
| P2R                       | 1-3 (P)               | 1-2         | 1-2          | 1-2                           | LOW          | LOW                              |                                                              |
| P2RD                      | 1-2 (P)               | 1           | 1            | 1                             | LOW          | LOW                              |                                                              |
| P3                        | 1-6 (P)               | 1-4         | 1-4          | 1-3                           | LOW-MID      | LOW-MID                          |                                                              |
| P3D                       | 1-6 (P)               | 1-4         | 1-4          | 1-3                           | LOW-MID      | LOW-MID                          |                                                              |
| P4                        | 1-6 (P)               | 1-4         | 1-4          | 1-3                           | LOW-MID      | LOW-MID                          |                                                              |
| <b>Endodontics</b>        |                       |             |              |                               |              |                                  |                                                              |
| E1                        | 1-3 (E)               | —           | —            | —                             | LOW          | —                                | Compatible with<br>WOODPECKER<br>& EMS<br>Ultrasonic Scalers |
| E2                        | 1-3 (E)               | —           | —            | —                             | LOW          | —                                |                                                              |
| E3                        | 1-6 (E)               | —           | —            | —                             | LOW          | —                                |                                                              |
| E3D                       | 1-3 (E)               | —           | —            | —                             | LOW          | —                                |                                                              |
| E4                        | 1-6 (E)               | —           | —            | —                             | LOW          | —                                |                                                              |
| E4D                       | 1-3 (E)               | —           | —            | —                             | LOW          | —                                |                                                              |
| E5                        | 1-6 (E)               | —           | —            | —                             | LOW          | —                                |                                                              |
| E5D                       | 1-3 (E)               | —           | —            | —                             | LOW          | —                                |                                                              |
| P4D                       | 1-6 (E)               | —           | —            | —                             | LOW          | —                                |                                                              |
| E8                        | 1-10 (E)              | —           | —            | —                             | LOW          | —                                |                                                              |
| E9                        | 1-10 (E)              | —           | —            | —                             | LOW          | —                                |                                                              |
| E10                       | 1-6 (E)               | —           | —            | —                             | LOW          | —                                |                                                              |
| E10D                      | 1-6 (E)               | —           | —            | —                             | LOW          | —                                |                                                              |
| E11                       | 1-6 (E)               | —           | —            | —                             | LOW          | —                                |                                                              |
| E11D                      | 1-6 (E)               | —           | —            | —                             | LOW          | —                                |                                                              |
| E14                       | 1-3 (E)               | —           | —            | —                             | LOW          | —                                |                                                              |
| E15                       | 1-3 (E)               | —           | —            | —                             | LOW          | —                                |                                                              |
| <b>Cavity Preparation</b> |                       |             |              |                               |              |                                  |                                                              |
| SB1                       | 1-10 (P)              | 1-7         | 1-7          | 1-6                           | LOW-MID      | LOW-MID                          | Compatible with<br>WOODPECKER<br>& EMS<br>Ultrasonic Scalers |
| SB2                       | 1-10 (P)              | 1-7         | 1-7          | 1-6                           | LOW-MID      | LOW-MID                          |                                                              |
| SB3                       | 1-10 (P)              | 1-7         | 1-7          | 1-6                           | LOW-MID      | LOW-MID                          |                                                              |
| SBL                       | 1-10 (P)              | 1-7         | 1-7          | 1-6                           | LOW-MID      | LOW-MID                          |                                                              |
| SBR                       | 1-10 (P)              | 1-7         | 1-7          | 1-6                           | LOW-MID      | LOW-MID                          |                                                              |

[NOTE] : "G" for the working mode of "Scaling"; "P" for the working mode of "Periodontics"; "E" for the working mode of "Endodontics"; "—" for "not suitable for such model of scaler".



Scan and Login website  
for more Information



Guilin Woodpecker Medical Instrument Co., Ltd.  
Information Industrial Park, National High-Tech  
Zone, Guilin, Guangxi, 541004 P. R. China

Tel:

Europe Sales Dept.: +86-773-5873196, +86-773-2125222

North America, South America &

Oceania Sales Dept.: +86-773-5873198, +86-773-2125123

Asia & Africa Sales Dept.: +86-773-5855350, +86-773-2125896

Fax: +86-773-5822450

E-mail: [woodpecker@glwoodpecker.com](mailto:woodpecker@glwoodpecker.com) [sales@glwoodpecker.com](mailto:sales@glwoodpecker.com)

Website: <http://www.glwoodpecker.com>



Wellkang Ltd ([www.CE-Marking.eu](http://www.CE-Marking.eu))  
29 Harley St., LONDON, W1G 9QR, UK