

CS 2100

User Guide

Notice

Congratulations on your purchase of the CS 2100. Thank you for your confidence in our products and we will do all in our power to ensure your complete satisfaction.

The User Guide for the CS 2100 includes information on the usage of the equipment. We recommend that you thoroughly familiarize yourself with this Guide in order to make the most effective use of your system.



WARNING: We recommend that you consult the “Safety, Regulatory and Technical Specification User Guide” before using the CS 2100.

No part of this Guide may be reproduced without the express permission of Carestream Dental LLC.

U.S. Federal law restricts this equipment to sale by or on the order of a dentist or physician.

This document is originally written in English.

Manual Name: *CS 2100 User Guide*

Part Number: SM759

Revision Number: 04

Print Date: 2022-09

The CS 2100 complies with the Medical Device Regulation (EU) 2017/745 and UK Medical Devices Regulations 2002 (SI 618) as subsequently amended by the EU Exit Regulations of 2019 (SI 791) and 2020 (SI 1478).



Contents







About This Guide	Conventions in this Guide	3
System Overview	General Overview.	5
	CS 2100 Unit Configurations	8
	Control Timer Unit	13
Radiology Process	Positioning	15
	Positioning the Patient.	15
	Positioning the X-Ray Generator	15
	Paralleling technique	15
	Bisecting technique.	15
	Positioning the Imaging Receptor.	16
	Exposure	16
	Exposure Parameters	16
	Exposure Times	17
	Exposure Times for Film.	17
	Exposure Times for Phosphor Plates.	17
	Exposure Times for Digital Sensors	18
	Emitted Doses	20
	Film Processing	21
Acquiring An Image	Preparing for Image Acquisition	23
	Launching the X-Ray	24
User Mode	Parameters	25
	Entering the User Mode	25
	Modifying Parameters	25
	Exiting the User Mode	26
	Performing a Tube Seasoning	26
	Automatic Tube Seasoning	26
	Manual Tube Seasoning	27
Troubleshooting	Quick Troubleshooting	29
	Information Messages	31
	Error Messages.	32
Maintenance	Quarterly	33
	Generator	33

	Mechanical support	33
	Control timer unit and electrical installation	33
	Operation	33
	Control timer unit self-test	33
	Annually	34
	Cleaning and Disinfecting the CS 2100	34
Contact Information	Manufacturer's Address	35
	Factory	35
	Authorized Representatives	35
	European Authorized Representative	35
	Authorized Representative in the European Union	35
	Responsible Person in the United Kingdom.	35
	List of Importers for European Union according to MDR 2017/745	35
	List of Importers for Switzerland	36

1 About This Guide

Conventions in this Guide

The following special messages emphasize information or indicate potential risk to personnel or equipment:

	WARNING Warns you to avoid injury to yourself or others by following the safety instructions precisely.
	CAUTION Alerts you to a condition that might cause serious damage.
	IMPORTANT Alerts you to a condition that might cause problems.
	NOTE Emphasizes important information.
	TIP Provides extra information and hints.
 	WARNING Exposure to ionizing radiation

2 System Overview

The CS 2100 is compliant with the requirements of the EEC and international medical standards.

The CS 2100 is equipped with a thermal safety system that prevents the generator from overheating in case of intensive use. This prohibits any exposure as long as the generator has not cooled down. The I01 error message appears on the display and an audible beep is heard during the unit cooling period. The beep stops when the cooling period is over.

To obtain high-quality intraoral radiography with maximum details, you must be very careful when performing the three steps of the radiography process:

- Positioning the patient, the X-ray generator, and the imaging system
- Setting the exposure parameters according to the imaging receptor used (films, phosphor plates or sensors)
- Processing the film (if a conventional film is used)

General Overview

The CS 2100 unit is composed of the following functional components

- A high-frequency X-ray generator which includes:
 - A transformer and associated electronics, and an oil-bathed X-ray tube
 - A beam-limiting device with the following characteristics:
 - A radiation diameter of 6 cm (2.36 in.)
 - A distance from the X-ray tube focal spot to skin of 20 cm (8 in.).
 - An angle scale and a handle to facilitate positioning.
- A wall framework which contains the:
 - Main powerboard
 - ON/OFF switch which contains a built-in LED.
- A control timer unit which:
 - Performs exposure time selection and displays parameters (exposure time and emitted dose).
 - Performs a microprocessor self-test at every unit activation.
 - Displays alarms in case of incorrect operation.
 - Includes two exposure time modes. The digital mode corresponds to the range of shortest exposure times that fit those needed for digital sensors.
- An extension arm and a scissor arm which is equipped with springs that ensure arm stability.

The following figure illustrates the extension arm and the scissor arm.

Figure 1 CS 2100 - Side View

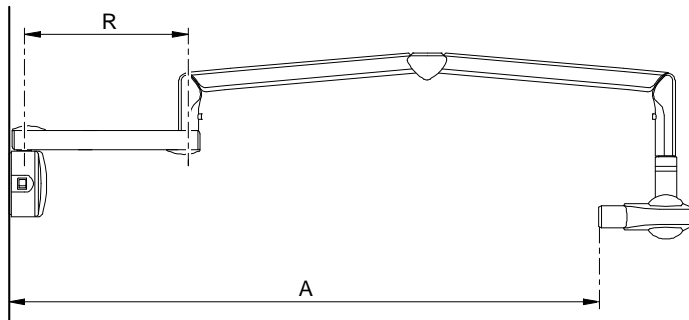

Table 1 Extension arm types

Extension	R	Span A
Short	47.0 cm (18.5 in.)	170.0 cm (67 in.)
Standard	64.8 cm (25.5 in.)	188.0 cm (74 in.)
Long	82.5 cm (32.5 in.)	205.0 cm (80.69 in.)

- A rectangular collimator. Its various sizes adapt to films, phosphor plates and RVG sensors. It is recommended to use such a collimator if possible, in order to limit the radiation absorbed by patients.

The CS 2100 unit is also composed of a remote exposure switch which is an optional accessory.

The following CS 2100 unit configurations are provided:

- Standard wall-mounted unit
- Ceiling-mounted unit.

The following mounting options are provided:

- Floor column base
- Mobile base



NOTE

These options must be used with a standard wall-mounted unit.

CS 2100 Unit Configurations

Figure 2 Standard Wall-Mounted Unit

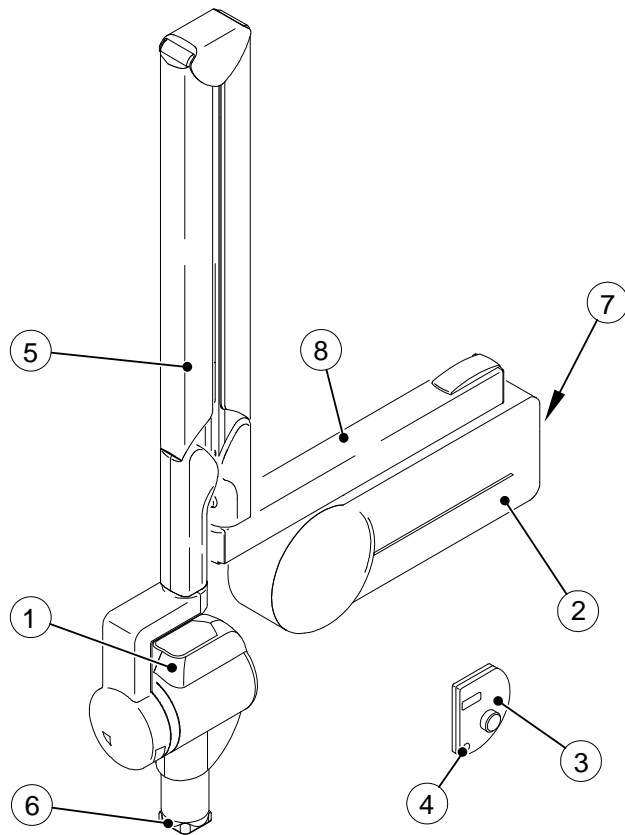

1	High frequency X-ray generator
2	Wall framework
3	Separate control timer unit
4	X-ray exposure button
5	Scissor arm
6	Rectangular collimator
7	ON/OFF switch with built-in LED
8	Extension arm

Figure 3 CS 2100 Unit with Separate Exposure Switch

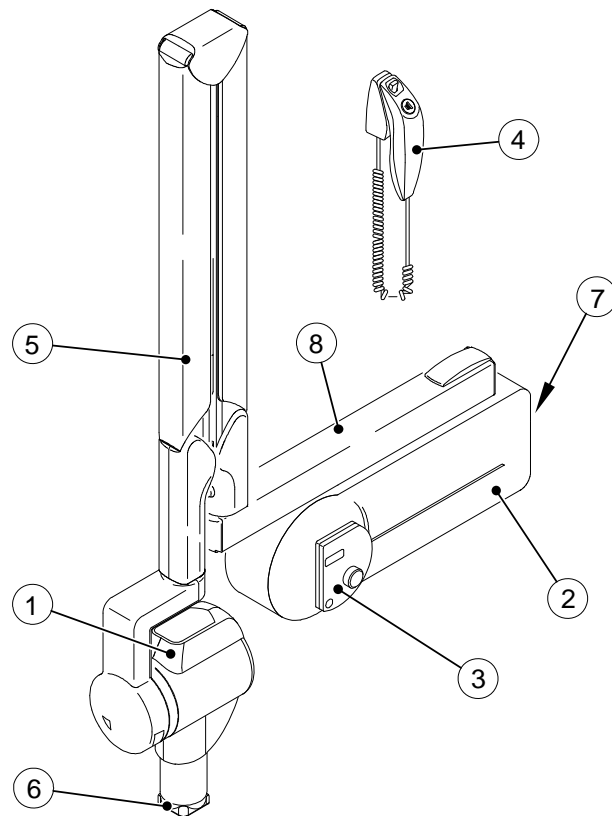

NOTE

This configuration is an optional configuration

1	High frequency X-ray generator
2	Wall framework
3	Control timer unit
4	X-ray exposure switch with X-ray exposure button
5	Scissor arm
6	Rectangular collimator
7	ON/OFF switch with built-in LED
8	Extension arm

Figure 4 Ceiling-Mounted Unit

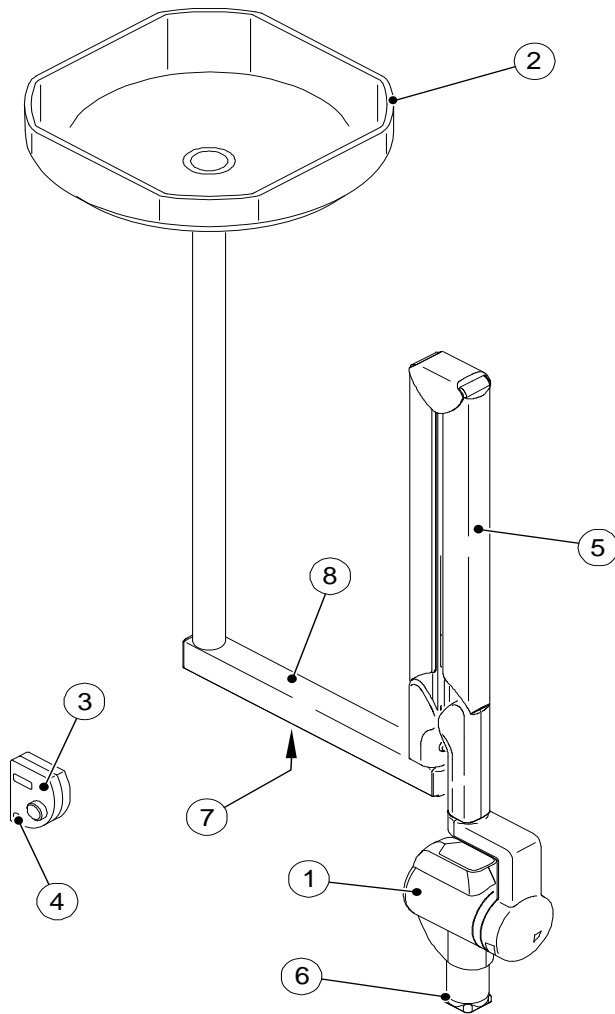

1	High frequency X-ray generator
2	Ceiling mounted unit containing the main powerboard
3	Control timer unit
4	X-ray exposure switch
5	Scissor arm
6	Rectangular collimator
7	ON/OFF switch with built-in LED
8	Extension arm

Figure 5 Unit Mounted on Floor Column

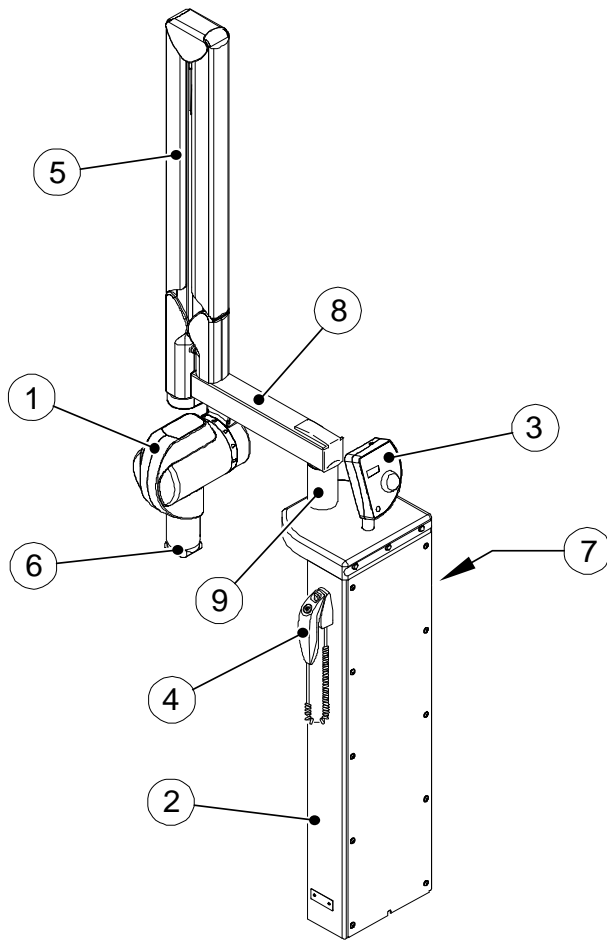

1	High frequency X-ray generator
2	Floor column containing the main powerboard
3	Control timer unit
4	X-ray exposure switch with X-ray exposure button
5	Scissor arm
6	Rectangular collimator
7	ON/OFF switch with built-in LED
8	Extension arm
9	Raiser

Figure 6 Unit Mounted on Mobile Base

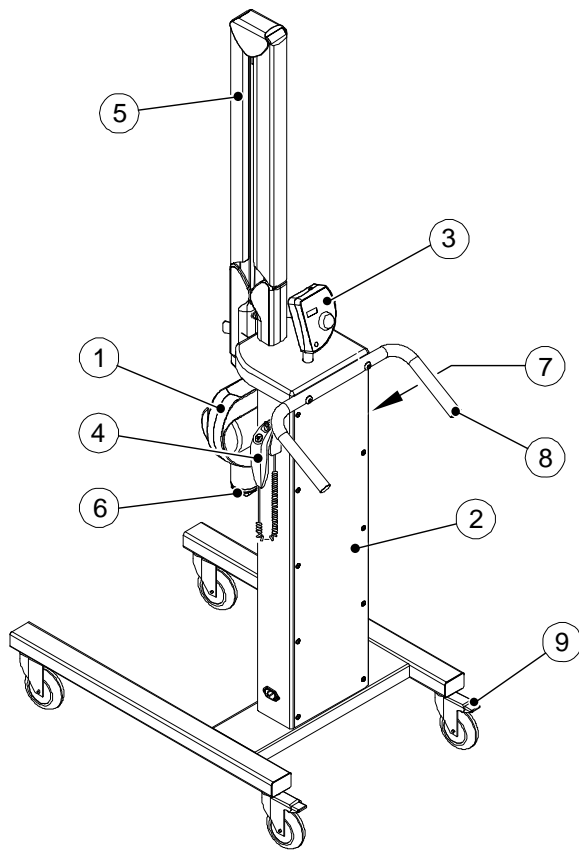

1	High frequency X-ray generator
2	Mobile stand containing the main powerboard
3	Control timer unit
4	X-ray exposure switch with X-ray exposure button
5	Scissor arm
6	Rectangular collimator
7	ON/OFF switch with LED
8	Handle
9	Foot brake

Control Timer Unit

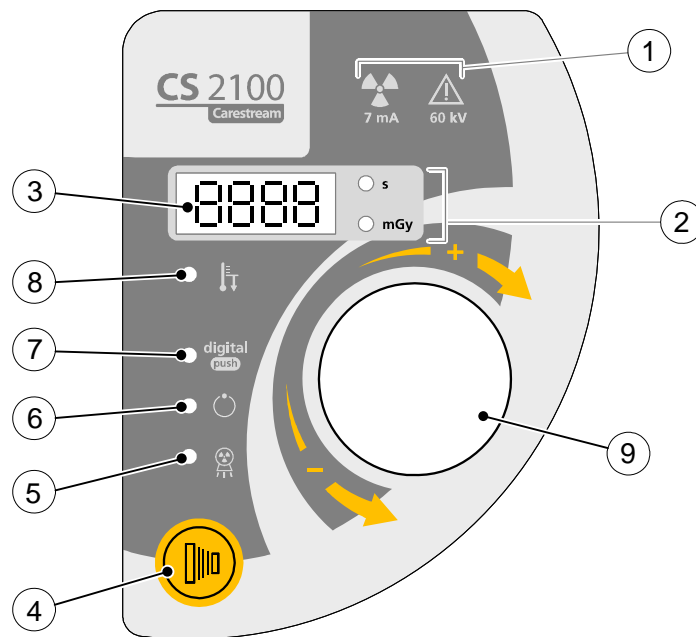

1	Warning: Ionizing radiation
2	Exposure time - emitted dose indicator
3	Display
4	X-ray exposure button
5	X-ray emission control light
6	Ready state
7	Exposure time selector: - Lit: shortest exposure times for digital sensors - OFF: longest exposure times for films and phosphor plates
8	Warning
9	Selection knob: - Press and hold the knob to activate the exposure time selector. - Rotate the knob to select the exposure time.

3 Radiology Process

Positioning

Positioning the Patient

To position the patient, you must have:

- The patient sit with the vertical sagittal plane.
- The patient's head positioned as follows:
 - For upper maxillary radiography, the Frankfort plane (nose-ear plane) must be horizontal.
 - For lower maxillary radiography, the occlusal plane must be horizontal.

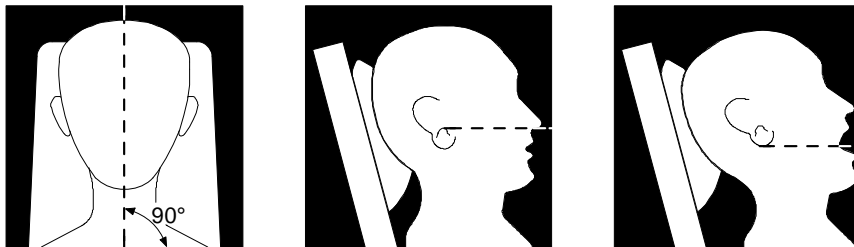

Positioning the X-Ray Generator

The scissor arm allows you to accurately position the generator for any type of exposure. The beam-limiting device maintains a distance of at least 20 cm (8 in.) between the focal spot and the skin, which allows you to use either the paralleling or the bisecting technique.

Paralleling technique

The positioning tool used in the paralleling technique allows you to align the beam and the imaging receptor. An appropriate collimator reduces the dosage by limiting the surface exposure.

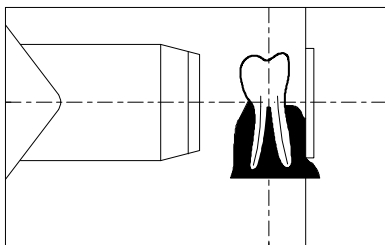

Bisecting technique

When using the bisecting technique, do not use a rectangular collimator. This limits the risk of X-ray beam and image receptor misalignment.

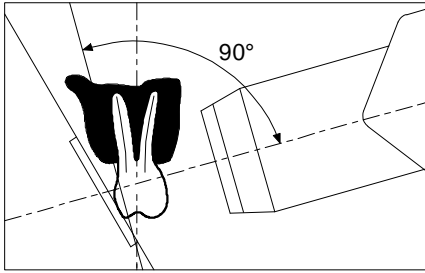

Positioning the Imaging Receptor

Using the CS 2100, you may create an X-ray image on one of the following imaging receptors:

- Conventional silver halide films, such as KODAK dental films.
- Digital sensors such as RVG sensors.
- Phosphor plate such as CS Imaging plates.

Placing the receptor correctly is critical. Check your own dental radiography manual for information on how to place the imaging receptor correctly.

If you do not position the film or the sensor correctly, this results in errors on the radiography, such as distorted teeth and roots, elongation, magnification, and/or overlapping contacts. The paralleling technique generally reduces the risk of such errors. However, if you do not position the system correctly, angulation errors can occur (angulation of the receptor to the tooth itself).

If the beam exit pattern is not aligned with the imaging receptor, then part of the radiography will not be exposed to radiation and the final radiography will have some clear (unexposed) areas. This defect is called “cone cuts”.

The imaging receptor is marked to indicate the tube side. If the orientation is not correct, the resulting radiography is lighter and may show artifacts, such as foil pattern or sensor cable.

Exposure

Exposure Parameters

Since each receptor (film, phosphor plate or digital sensor) has its own sensitivity to X-ray radiation, the sensor choice impacts the exposure parameters. For instance, the sensitivity class for conventional dental films is characterized with the letter D, E, or F where F is more sensitive than E, and E more sensitive than D. Consequently, the required dose for the correct exposure goes down as sensitivity increases.

Due to the different sensitivity of the digital sensors, you also need to adjust the exposure parameters to the used sensor type (film or digital equipment).

The CS 2100 allows you to select the exposure times. The exposure times indicated in Tables 3-1 to 3-4 meet the manufacturer’s recommendations. Depending on the used sensor type, you can change the mode by pressing and holding the selection knob for at least three seconds. To set the exposure times, see the ***Preparing for Image Acquisition*** section.

Exposure Times

Exposure Times for Film

The indicated exposure times are given as a guideline.

Table 2 Exposure Times for Film

60 kV - 7 mA - Cone 20 cm (8 in.)										
		Maxillary			Mandibular			Bitewing		Occlusal
		Anterior	Premolar	Molar	Anterior	Premolar	Molar	Anterior	Posterior	
ULTRA-SPEED (D)	Child	0.250	0.320	0.400	0.200	0.250	0.250	0.200	0.250	0.500
	Adult	0.400	0.500	0.630	0.320	0.400	0.400	0.320	0.400	0.630
INSIGHT (F)	Child	0.100	0.125	0.160	0.080	0.100	0.100	0.080	0.100	0.200
	Adult	0.160	0.200	0.250	0.125	0.160	0.160	0.125	0.160	0.250
D-SPEED	Child	0.250	0.320	0.400	0.200	0.250	0.250	0.200	0.250	0.500
	Adult	0.400	0.500	0.630	0.320	0.400	0.400	0.320	0.400	0.630
E-SPEED	Child	0.125	0.160	0.200	0.100	0.100	0.125	0.100	0.125	0.200
	Adult	0.200	0.250	0.250	0.160	0.160	0.200	0.160	0.200	0.320

Exposure Times for Phosphor Plates

The indicated exposure times are given as a guideline.

Table 3 Exposure Times for Phosphor Plates

60 kV - 7 mA - Cone 20 cm (8 in.)										
		Maxillary			Mandibular			Bitewing		Occlusal
		Anterior	Premolar	Molar	Anterior	Premolar	Molar	Anterior	Posterior	
CR7400	Child	0.250	0.320	0.400	0.200	0.250	0.250	0.200	0.250	0.500
	Adult	0.400	0.500	0.630	0.320	0.400	0.400	0.320	0.400	0.630
CS7600	Child	0.160	0.200	0.250	0.125	0.160	0.160	0.125	0.160	0.320
	Adult	0.250	0.320	0.400	0.200	0.250	0.250	0.200	0.250	0.500

Exposure Times for Digital Sensors

The indicated exposure times are given as a guideline.

Table 4 Exposure Times for Digital Sensors

60 kV - 7 mA - Cone 20 cm (8 in.)										
		Maxillary			Mandibular			Bitewing		Occlusal
		Anterior	Premolar	Molar	Anterior	Premolar	Molar	Anterior	Posterior	
RVG 5100	Child	0.100	0.125	0.160	0.080	0.080	0.100	0.080	0.100	0.160
	Adult	0.160	0.160	0.200	0.125	0.125	0.160	0.125	0.160	0.250
RVG 5200 (size 1& 2)	Child	0.100	0.125	0.160	0.080	0.080	0.100	0.080	0.100	0.160
	Adult	0.160	0.160	0.200	0.125	0.125	0.160	0.125	0.160	0.250
RVG Element (size 1& 2)	Child	0.100	0.125	0.160	0.080	0.080	0.100	0.080	0.100	0.160
	Adult	0.160	0.160	0.200	0.125	0.125	0.160	0.125	0.160	0.250
RVG 5000	Child	0.100	0.125	0.160	0.080	0.080	0.100	0.080	0.100	0.160
	Adult	0.160	0.160	0.200	0.125	0.125	0.160	0.125	0.160	0.250
RVG Access	Child	0.100	0.125	0.160	0.080	0.080	0.100	0.080	0.100	0.160
	Adult	0.160	0.200	0.200	0.125	0.125	0.160	0.125	0.160	0.250
RVG 6500	Child	0.080	0.100	0.125	0.063	0.080	0.080	0.063	0.080	0.125
	Adult	0.125	0.160	0.200	0.125	0.160	0.160	0.100	0.125	0.200
RVG 6100 (size 1& 2)	Child	0.080	0.100	0.125	0.063	0.080	0.080	0.063	0.080	0.125
	Adult	0.125	0.160	0.200	0.125	0.160	0.160	0.100	0.125	0.200
RVG 6200 (size 1& 2)	Child	0.080	0.100	0.125	0.063	0.080	0.080	0.063	0.080	0.125
	Adult	0.125	0.160	0.200	0.125	0.160	0.160	0.100	0.125	0.200
RVG Exclusive (size 1& 2)	Child	0.080	0.100	0.125	0.063	0.080	0.080	0.063	0.080	0.125
	Adult	0.125	0.160	0.200	0.125	0.160	0.160	0.100	0.125	0.200
RVG 6000	Child	0.080	0.100	0.125	0.063	0.080	0.080	0.063	0.080	0.125
	Adult	0.125	0.160	0.200	0.125	0.160	0.160	0.100	0.125	0.200
TROPHY RVG Ultimate	Child	0.080	0.100	0.125	0.063	0.080	0.080	0.063	0.080	0.125
	Adult	0.125	0.160	0.200	0.100	0.100	0.125	0.100	0.125	0.200
TROPHY RVG Reference High Resolution mode	Child	0.080	0.100	0.125	0.063	0.063	0.080	0.063	0.080	0.125
	Adult	0.125	0.160	0.160	0.100	0.100	0.125	0.100	0.125	0.200
TROPHY RVGui High Resolution mode	Child	0.080	0.100	0.125	0.063	0.063	0.080	0.063	0.080	0.125
	Adult	0.125	0.160	0.160	0.100	0.100	0.125	0.100	0.125	0.200

TROPHY RVG Reference High Sensitive mode	Child	0.020	0.025	0.032	0.016	0.020	0.020	0.016	0.020	0.040
	Adult	0.032	0.040	0.050	0.025	0.032	0.032	0.025	0.032	0.050
TROPHY RVGui High Sensitive mode	Child	0.020	0.025	0.032	0.016	0.020	0.020	0.016	0.020	0.040
	Adult	0.032	0.040	0.050	0.025	0.032	0.032	0.025	0.032	0.050
TROPHY RVG THD	Child	0.040	0.050	0.063	0.032	0.040	0.040	0.032	0.040	0.080
	Adult	0.063	0.080	0.100	0.050	0.063	0.063	0.050	0.063	0.100
RVG 6100 size 0	Child	0.040	0.050	0.063	0.032	0.040	0.040	0.032	0.040	0.080
	Adult	0.063	0.080	0.100	0.050	0.063	0.063	0.050	0.063	0.100

The following table is a template that you may fill in according to your specific conditions.

Table 5 Customized Table for Exposure Times

60 kV - 7 mA - Cone 20 cm (8 in.)										
		Maxillary			Mandibular			Bitewing		Occlusal
		Anterior	Premolar	Molar	Anterior	Premolar	Molar	Anterior	Posterior	
	Child									
	Adult									
	Child									
	Adult									

Emitted Doses

To obtain the dose in mGy.cm², multiply the values listed in [Table 6](#) by the exposure surface. The exposure surface depends on the used collimator type as indicated in [Table 7](#).

Table 6 Measured Dose at the End of the 20 cm (8 in.) Cone

60 kV - 7 mA			
t (s)	D (mGy)	t (s)	D (mGy)
0.010	0.06	0.200	1.22
0.013	0.08	0.250	1.52
0.016	0.10	0.320	1.95
0.020	0.12	0.400	2.44
0.025	0.15	0.500	3.05
0.032	0.19	0.630	3.84
0.040	0.24	0.800	4.87
0.050	0.30	1.000	6.09
0.063	0.38	1.250	7.61
0.080	0.49	1.600	9.74
0.100	0.61	2.000	12.18
0.125	0.76	2.500	15.23
0.160	0.97		



NOTE

Dose accuracy: +/- 30% (mGy)

Table 7 Exposure Surface versus Collimator Type

Collimator type	Format (cm)	Used with films (cm)	Exposure surface (cm ²)
A	1.9 x 2.4	-	4.6
B	2.3 x 3.5	Size 0: 2.2 x 3.5	8.3
C	3.1 x 3.9	Size 1: 2.4 x 4.0 Size 2: 3.1 x 4.1	12.1
Standard cone	6.0 cm diameter	Size 3: 2.7 x 5.4 Size 4: 5.7 x 7.6	28.3

Film Processing

When using films, you must process the film according to the manufacturer's instructions. Process the film under safelight conditions manually or using an automatic processor.

If you use an automatic processor, see the processor's manual. Check that the processor maintenance is performed regularly.

If you process the film manually, follow precisely the manufacturer's recommendations for solution preparation, processing time, and solution temperature for both the developer and the fixer baths. Any deviation from the manufacturer's recommendations (such as a solution that would be too concentrated or diluted, too hot or cold, or if the film processing duration is incorrect) will impact the final radiography quality.

Before archiving, do not forget to wash the film correctly and to dry it in a clean place.

4 Acquiring An Image

This chapter describes the various tasks that you must perform for image acquisition. To acquire an image, you can use conventional films or digital receptors.

If necessary, for example after a long inactivity period of the CS 2100 system, we recommend to start with the tube seasoning procedure. For more information, see the **Tube Seasoning Procedure**.

Preparing for Image Acquisition

To prepare for image acquisition, follow these steps:

- 1 Switch ON the unit.

The green ON/OFF button indicator lights up.

When you switch ON the unit, a self-test starts automatically. It checks the display. When the test is completed, a short beep sounds. If an error occurs, an error code appears. For error messages, see the **Troubleshooting** section.

- 2 Select the exposure mode (film or digital) by pressing and holding  for at least three seconds until the correct mode is displayed. The indicator lights up if you use a digital sensor whereas it is OFF if you use a film.



NOTE

Depending on your local regulations, you may disable this function. See the **User Mode** section.

- 3 Turn  to select the exposure time.

For more information on exposure times, see Tables 3-1, 3-2, 3-3, and 3-4.



NOTE

- Exposure time ranging from 0.05 to 1.25 s (exposure selector off): if you use a film or a storage phosphor plate.

- Exposure time ranging from 0.010 to 0.063 s (exposure selector lit): if you use a digital sensor.

The unit is now ready for acquisition.



IMPORTANT

The operator must instruct the patient to refrain from moving during the entire exposure.

Launching the X-Ray

To launch the X-ray, follow these steps:



WARNING

Be careful not to be exposed to ionizing radiation

- 1 Press  from the control timer unit or from the X-ray exposure switch.

The X-ray emission indicator lights up and a beep is heard.

- 2 Keep pressing  until the X-ray emission indicator is OFF and the beep stops.

During the X-ray emission, the exposure time counts off on the display.



CAUTION

If you release the button before the end of the X-ray, a manipulator alarm (E01) is enabled.

This indicates that the X-ray emission was aborted prematurely. There is an underexposure risk. Depending on the remaining time, you can decide to process the image or start a new image acquisition.

To stop the alarm, press on  from the control timer unit.

When the acquisition is completed, the emitted dose is displayed in mGy. The “mGy” indicator lights up. For information on the emitted doses based on the exposure times, see Table 3-5. The latest parameter settings are kept until a new image acquisition is performed.

- 3 Press on  shortly to change from mGy to exposure time display.

5 User Mode

This chapter describes the various settings that you can select for the different pre-set modes. The user mode also allows you to validate specific local requirements for some countries.

Parameters

Table 8 Parameters Available through the User Mode

Number	Parameters	Choice
P 01	Digital receptor	ON/OFF (needed for correct emitted dose display)
P 05	Tube seasoning procedure	Switches from OFF to ON
P 06	Show mode	ON: Disables the X-ray emission OFF (default value): Enables the X-ray emission

Entering the User Mode

To enter the user mode, follow these steps:

- 1 Switch ON the unit.

The self-test is enabled. While the self-test is in progress, the software information (for example, F718 x.x) is displayed.

- 2 Once F718 x.x is displayed, press shortly on  from the control timer unit.

You access the menu, when "USER" is displayed. The display intermittently shows the first parameter (P 01) and its setting (for example, "ON").

- 3 To switch from one parameter to the other, turn  in any direction.

Modifying Parameters

To modify parameters, follow these steps:

1 Turn  to select the parameter to modify.

2 Press on  until "EDIT" is displayed and a beep is heard.

The parameter value starts blinking.

3 Turn  to change the parameter value.

4 To validate, press and hold  for at least 3 seconds until "COPY" is displayed and a beep is heard.

5 To keep the initial value, press on  shortly. "ABOR" is displayed. The system returns to the parameter/program mode.

Exiting the User Mode

To exit the user mode, press on  shortly. "QUIT" is displayed until the system returns to the operational mode. The self-test continues until it is completed.

Performing a Tube Seasoning

Automatic Tube Seasoning

This procedure allows for a progressive warm-up of the X-ray tube. It must be performed at unit installation and when replacing the tube head. It must also be performed, for instance, after 3 weeks of equipment inactivity. It lasts around three minutes.

To perform an automatic tube seasoning, follow these steps:

1 Go to the User Mode menu and change parameter P 05 from OFF to ON.

The self-test continues. After the self-test is completed, I 02 is displayed. This message means that the seasoning process must be started.

2 Press on  .

The display blinks. The sequence step number and the required exposure settings (kV, time) are displayed alternatively.

3 Stand behind the generator.

4 Launch an X-ray.



WARNING

Be careful not to be exposed to ionizing radiation

When the exposure is completed, the display blinks. The cooling error code (I 01) and the remaining time required before the next step are displayed alternatively.

When the cooling cycle is completed, the display blinks. The next step number and its exposure settings are displayed alternatively.

5 Repeat steps 3 and 4 until the end of the sequence.

Your system is ready.

Manual Tube Seasoning

To perform a manual tube seasoning, follow these steps:

- 1 Select the following series of parameter settings: 60 kV - 7 mA - 0.1 s. Launch an X-ray.
- 2 Select the following series of parameter settings: 60 kV - 7 mA - 0.5 s. Launch an X-ray.
- 3 Select the following series of parameter settings: 60 kV - 7 mA - 1 s. Launch an X-ray.
- 4 Select the following series of parameter settings: 60 kV - 7 mA - 1 s. Launch an X-ray.



IMPORTANT

If you receive error messages while you carry out the procedures, switch OFF and ON the unit and do all the procedures again.

If the error messages persists, contact your representative.

6 Troubleshooting

Occasionally, malfunctions can occur during use in the event of an incorrect action or failure. The quick troubleshooting, the Information “Ixx” and Error message “Exx” guide you through the actions you need to take to correct the malfunction.



IMPORTANT

If the malfunction persists or more serious conditions occur, switch OFF the unit power supply and contact your representative.

When you call your representative, you must have the following information ready:

- Model Number: CS 2100
- Serial Number (on the labels)
- Error Code Number: Exx.

Quick Troubleshooting

Quick troubleshooting guides you through the actions you need to take to correct the malfunctions.

The following table lists the malfunctions and the actions to take.

Table 9

Malfunction	Possible Cause	Action
Nothing lights up	The unit power switch is OFF.	Switch ON the unit.
	The unit is disconnected.	Connect the unit power supply cable.
	The circuit breaker is OFF.	Turn ON the circuit breaker.
Control unit doesn't light up.	The control unit is defective or disconnected.	Call your representative.
No X-ray emission	The generator is cooling	Wait until the I01 message is no longer displayed.
	The X-ray exposure button is defective.	Call your representative.

Table 9

Malfunction	Possible Cause	Action
The X-ray emission works, but the exposure is too light or completely white.	The generator is not positioned correctly.	Adjust the generator position
	The exposure time is too short.	Increase the exposure time.
	The development time is too short.	Increase the development time (See the manufacturer's instructions).
	The developer is too cold.	Heat the developer
	The developer is too old or diluted.	Replace with a new developer
	The exposure time mode is not correctly selected	Check your exposure settings (See the exposure procedure).
	The receptor is not correctly positioned.	Reposition the receptor.
	The unit is not correctly installed.	Call your representative.
The X-ray emission works but exposure is too dark.	The exposure time is too long.	Reduce the exposure time.
	The development time is too long.	Reduce the development time (See the manufacturer's instructions).
	The developer is too hot.	Cool the developer
	The developer is too concentrated.	Adjust the concentration or change developer.
	The exposure time mode is not correctly selected.	Check your exposure settings (See the exposure procedure).

Information Messages

An information “I” error code with a message appears on the display.

The following table lists the information messages and the actions to take.

Table 10 Information Messages

Information Code	Possible Cause	Action
I 01	Cooling cycle: this message can appear during intensive use period.	Do not switch OFF the equipment. The information message disappears as soon as the system reaches a satisfactory temperature.
I 02	Request for X-ray tube seasoning.	See the User Mode section.



IMPORTANT

If you switch OFF the system, the microprocessor does not calculate the cooling time. For safety reasons, it considers that the system has not gone through the cooling cycle.

Error Messages

The following table lists the error messages and the actions to take.

Table 11

Error Message	Possible Cause	Action
E01 + audible alarm	The radiography control button was released before the exposure end. The display indicates the remaining exposure time. Based on this time, you must decide whether to develop the film or make another exposure.	Quickly press on the selection knob to stop the alarm.
E02 to E54	A component of your device may be faulty	Switch OFF, then restart the system. If the problem persists, contact your representative.

7 Maintenance

This chapter describes the maintenance tasks you must perform for your CS 2100.

Quarterly

Generator

Check that:

- The certification label is legible.
- No oil leaks.

Mechanical support

Check that:

- The wall framework is securely attached to the wall.
- All labels are legible.
- The scissor arm is not worn out or damaged and is stable in all positions.
- The scissor arm plastic covers are firmly in place.

Control timer unit and electrical installation

Check that:

- The symbols are legible.
- The control timer unit and the power supply cables are in good condition.
- The X-ray exposure button returns to its initial position after use.

Operation



WARNING

Be careful not to be exposed to ionizing radiation

Check that:

- The audible signal is heard and the X-ray emission indicator is visible when you launch an X-ray (exposure time: 0.1 sec).
- The “E01” message is displayed when you launch an X-ray (exposure time: 1.0 sec) and you release the control button before the exposure end.

Control timer unit self-test

To enable the self-test, you must switch ON the CS 2100 system.

- The self-test starts with a simultaneous display and alarm light test.
- Then, the system test starts. After the test is completed (indicated by a short beep), the firmware version and the total number of exposures (divided by 10) performed by the unit since first installation are displayed.

- If the test fails, an error message is displayed.



IMPORTANT

If a check result is not satisfactory, stop using the equipment and contact your representative.

Annually

We recommend that an electrical, mechanical and dosimetric inspection of the unit be carried out by an authorized service technician provided by your representative.

Cleaning and Disinfecting the CS 2100



IMPORTANT

You must first clean the system before disinfection.

To clean the system, follow these steps:

- 1 Clean the outside of the equipment with a damp paper towel or a soft cloth using an alcohol-based, non-corrosive cleaner.
- 2 Wipe off surfaces with either an intermediate disinfectant or a low-level disinfectant.



CAUTION

- Liquids must not drip into the equipment.
- Do not spray cleaner or disinfectant directly on the equipment.
- Follow the manufacturer's safety recommendations when using a cleaner or a disinfectant.

8 Contact Information

Manufacturer's Address



Carestream Dental LLC
3625 Cumberland Boulevard, Suite 700,
Atlanta, GA USA 30339

Factory

Trophy

4, Rue F. Pelloutier, Croissy-Beaubourg
77435 Marne-la-Vallée Cedex 2, France

Authorized Representatives

European Authorized Representative

EC REP

TROPHY

4, Rue F. Pelloutier, Croissy-Beaubourg
77435 Marne la Vallée Cedex 2, France

Authorized Representative in the European Union

Trophy

4, Rue F. Pelloutier, Croissy-Beaubourg
77435 Marne-la-Vallée Cedex 2, France

Responsible Person in the United Kingdom

Carestream Dental Ltd

Jessica Igies-Mikaelson
Wiltron House, Rutherford Close Stevenage, Hertfordshire
SG1 2EF
England, United Kingdom

List of Importers for European Union according to MDR 2017/745

Carestream Dental France SAS

4 rue F. Pelloutier, Croissy-Beaubourg, 77435 Marne-la-Vallée Cedex 2, France

Carestream Dental Germany GmbH

Hedelfinger Str. 60, 70327 Stuttgart, Germany

Carestream Dental Spain

S.L.U. Paseo de la Castellana, 79, Madrid 28046, España

Carestream Dental Italy S.r.l.

Via Mario Idiojmi 3/3, Assago 20090 (MI), Italia

List of Importers for Switzerland**CURADEN AG**

Riedstrasse 12
CH-8953 Dietikon
Switzerland

Dema dent AG

Furtbachstrasse 16
CH-8107 Buchs
Switzerland

Jordi Röntgentechnik AG

Dammstrasse 70
CH-4142 Münchenstein
Switzerland

E. Schweizer AG

Bernerstrasse Nord 182
CH-8064 Zürich
Switzerland